



WILDTOP

INSTALLATION GUIDE



BEAST

Part No: WTB11915/R/TR/TSR













**Ford F-250/F-350, 2017-2022,
6.75ft Box (81.9 in)**

OVERVIEW OF COMPONENTS

	PART	DESCRIPTION	QTY	ILLUSTRATION
BRACKETS	Base Outer Bracket	Connects the Angled Frame Legs to the Base Longitudinal Rail, providing external structural support.	x2 Left x2 Right	
	Base Inner Bracket	Connects the Angled Frame Legs to the Base Longitudinal Rail from the inside, used with the Base Outer Bracket.	x2 Left x2 Right	
	Top Bracket	Attaches the top of the Angled Frame Legs to the frame, securing the Top Cross Rails and stabilizing the frame.	x2 Left x2 Right	
	Corner Rail Connector	Cast aluminium joiner for corner connections between Frame Rails (longitudinal and cross), providing critical support.	4	
	Clamp	These Clamps secures the Base Longitudinal Rail to the truck bed. Each Clamp includes two aluminium Clamp components, a Bolt and a Spring Washer.	4	
FRAME RAILS	Roof Support Rod with End Caps	Keeps water and snow running off the canvas. They are attached to the Top Longitudinal Rails.	4	
	Angled Frame Leg with Velcro	Connects Base and Top Brackets via Corner Rail Connectors. Velcro helps secure and tighten the canvas.	4	
	Top Longitudinal Rail with Press Studs	Runs lengthwise across the top of the frame, connecting the Front and Rear Hoops. Canvas straps attach via press studs.	2	
	Top Cross Rail with Press Studs	Spans the width of the frame, connecting left and right sides to form Front and Rear Hoops. Canvas straps attach via Press Studs.	2	
	Base Longitudinal Rail	Mounted at the bottom of the frame, it connects the structure to the truck bed. Plastic end caps are fitted on each end. It has a rubber strip that faces the bed.	2	
RACKS	East-West (E-W) Ladder Rack Rail	Mounts to the frame exterior and runs side-to-side. Supports loads and connects to Ladder Rack Connectors.	2	
	North-South (N-S) Ladder Rack Rail	Mounts to the frame exterior and runs front-to-back. Supports loads and connects to Ladder Rack Connectors.	2	
	Ladder Rack Connector	Mounts the Ladder Rack Rails to the frame and links with the Corner Rail Connectors to secure the ladder rack system. Includes an internal channel for routing cables from the exterior into the truck cap.	4	
CANVAS	Canvas Tension Rods	Insert into internal canvas pockets to keep the canvas taut. The tailgate rod is sometimes a different length than the two side rods, depending on model.	3	
	Magnetic Straps	Magnetic canvas straps with press studs to hold the canvas in place when rolled up.	6	
	WildTop Truck Cap	Premium and Patented Canvas Truck Cap	1	

HARDWARE IN THE BOX

Note: Our kits are standardized to minimize packing errors. As a result, some additional hardware may be included but not required for your specific installation.

											
A	B	C	D	E	F	G	H	I	J	K	L
M10 x 60mm Button Bolt	M8 x 12mm Button Bolt	M10 Nut	M8 Washer	12mm Self Tapping Screw	3M Paint Protection Disk	M10 x 150mm Hex Bolt	M10 Fibre Washer	M10 Washer	Rubber Gasket	Cleaning Wipe	Velcro (Hook)
40 pcs	16 pcs	44 pcs	16 pcs	8 pcs	6 pcs	4 pcs	4 pcs	40 pcs	4 pcs	2 pcs	2 pcs

TOOLS REQUIRED



Drill



Phillips Head



Drill Bit
Ø 3mm



Hex Keys
5mm & 6mm



17mm
Wrench

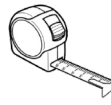

Tape
Measure



Marker



Clean Wiping
Cloth

IMPORTANT SAFETY SUMMARY

- Always wear appropriate Personal Protective Equipment (PPE).
- Follow all standard U.S. automotive and dealership procedures during installation.
- Refer to the vehicle's workshop manual when removing or reinstalling components.
- Do not use power tools to tighten nuts and bolts during assembly.
- Use hand tools only to prevent over-tightening or damage unless specifically directed.
- **Improperly fitted vehicle accessories can cause serious safety hazards.**
- **Please read these instructions carefully and follow them exactly during installation.**
- **If you are unsure about any step, do not proceed without seeking professional assistance.**



GLOSSARY



Repeat The Process
On The Other Side



Two People Required



Check Carefully



This Way Up

Start Here → INSTALLATION SUMMARY

- 1 Prepare a clean assembly area.**
Do not begin assembly on the truck. Use a large, flat surface – ideally a table. If no table is available, use a clean garage floor with a mat or cloth to prevent scratching components.
- 2 Assemble the Front and Rear Hoops**
Build two identical frame “hoops” – one for the front and one for the rear. These will form the structural ends of the frame.
- 3 Connect the Hoops using the Top Longitudinal Rails.**
This step joins the front and rear hoops to create the main frame structure.
- 4 Attach the Bottom Longitudinal Rails to the Truck Bed.**
The bottom rail connects directly to the truck bed using either Clamps or L-Bracket depending on your installation.
- 5 Install the Roof Support Rods.**
These prevent water from pooling on the roof canvas by applying upward tension.
- 6 Mount the assembled frame onto the truck bed.**
With the help of a second person, carefully position the frame, ensuring it is properly aligned and securely seated on the vehicle.
- 7 Drape the canvas over the frame.**
Once in place insert the tension rods into the inbuilt pockets.
- 8 Fit the exterior Ladder Rack Rails up top.**
Once installed, double-check that all hardware is tightened. Ensure the canvas is smooth and taut, with no bunching, and verify that the Velcro is properly aligned – this indicates the cap is correctly positioned.

STEP 1 - ASSEMBLE THE FRONT HOOP

☑ Completed View

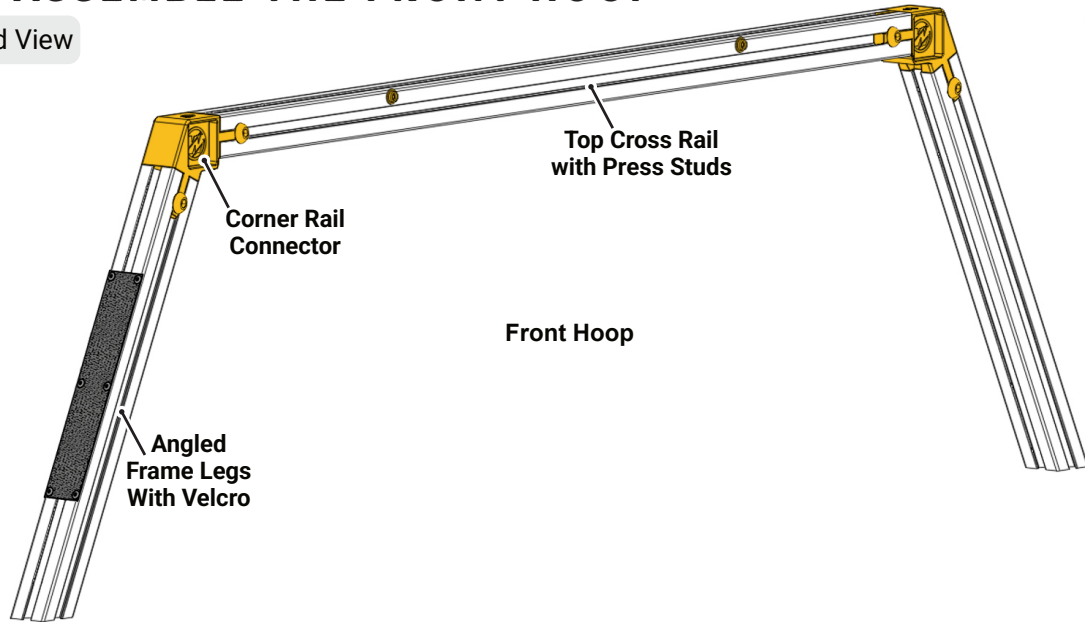

STEP 1.1 - Put the Top Cross Rail and two Corner Rail Connectors together

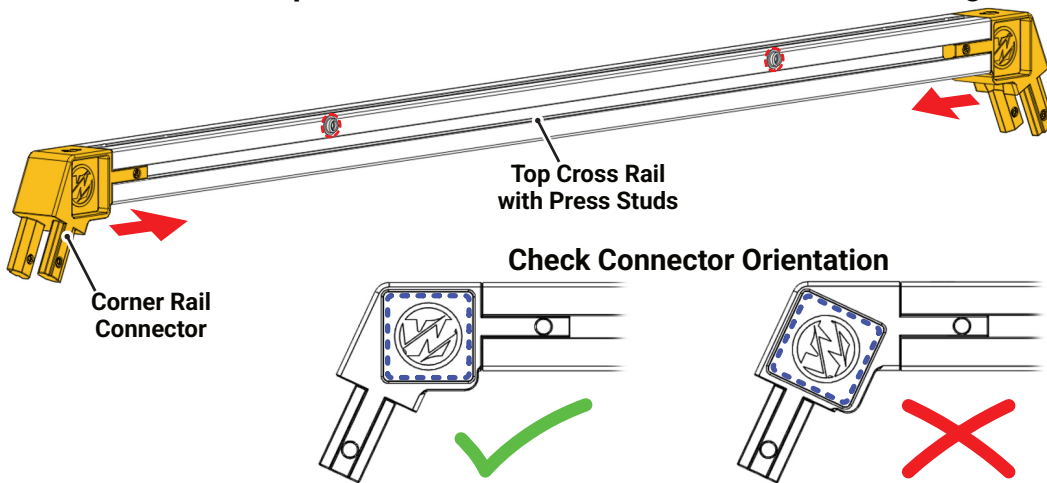

- Start with the Top Cross Rail and connect them into the Corner Rail Connector ensuring the orientation of press studs are on the top edge of the Top Cross Rail.
- The Corner Rail Connectors must be orientated in the correct way so that the WILDTOP 'W' logo has a level horizontal orientation.

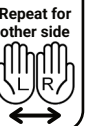

STEP 1.2 - Attach the Angled Frame Legs to the Corner Rail Connectors

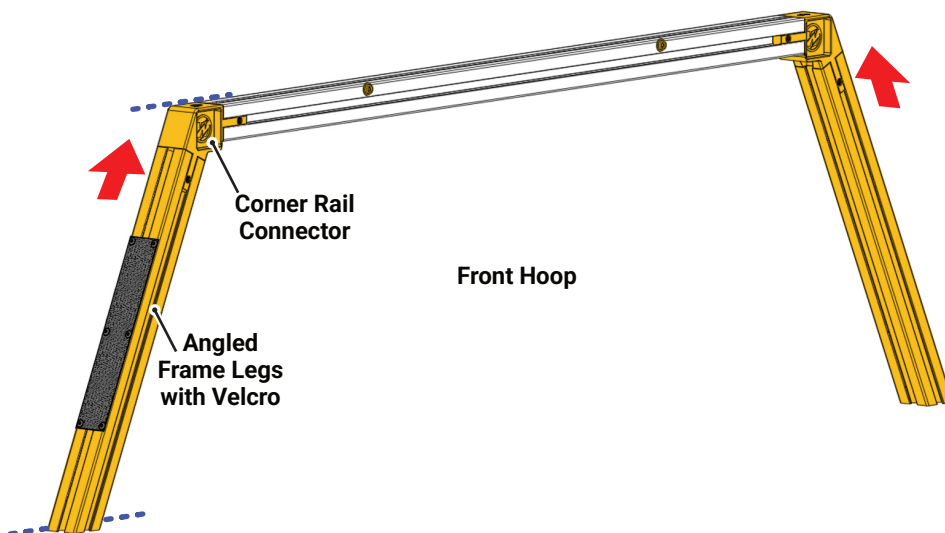

- Add the Angled Frame Legs with Velcro to the Corner Rail Connectors, making sure that the Velcro on the Angled Frame Legs are facing outwards. The base of the legs should be parallel with the Top Cross Rail.

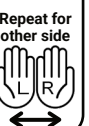

STEP 1.3 - Fasten Corner Rail Connectors with M8 Bolts and Washers

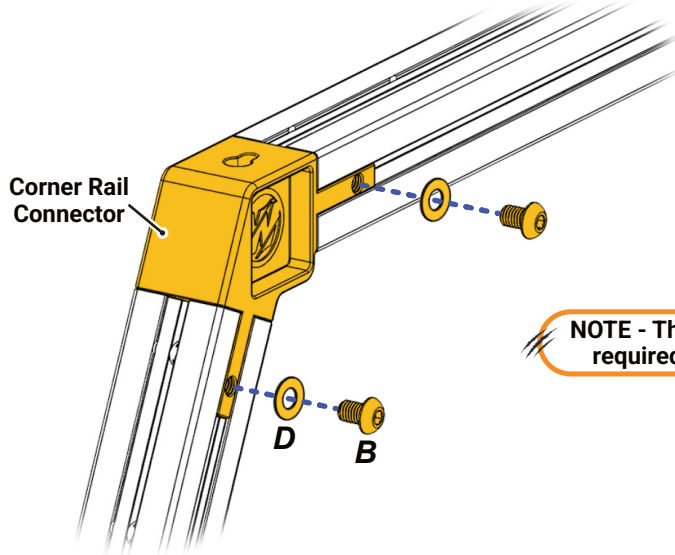

NOTE - The M8 Bolts and M8 Washers are required only on one side of the hoop.

Next, fasten 2x M8 Bolts with M8 Washers into the two inner fingers of the Corner Rail Connectors. These act as anti-rattle fasteners. Repeat for the other corner.

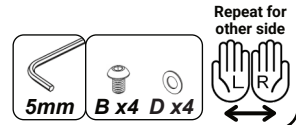

STEP 2 - ATTACH THE TOP BRACKETS TO THE FRONT HOOP

Completed View



STEP 2.1 - Attach Top Brackets to Front Hoop with M10 Bolts, Washers and Nuts

Press studs need to face inwards, towards the truck bed, in direction of Top Bracket.

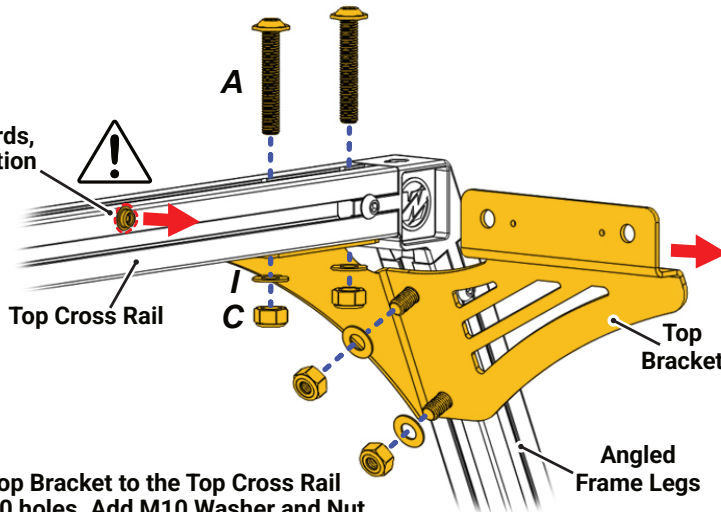

Using 4x M10 Bolts, attach one side of the Top Bracket to the Top Cross Rail and Angled Frame Leg using the pre-drilled M10 holes. Add M10 Washer and Nut to the inside. Tighten. Repeat for other side.

Note: The slotted holes of the Top Bracket must sit against the Top Cross Rail (not the Angled Frame Leg).

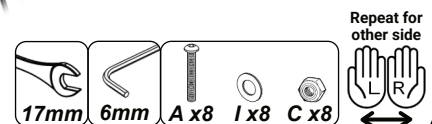

STEP 3 - ATTACH THE BASE BRACKETS TO THE FRONT HOOP

Completed View

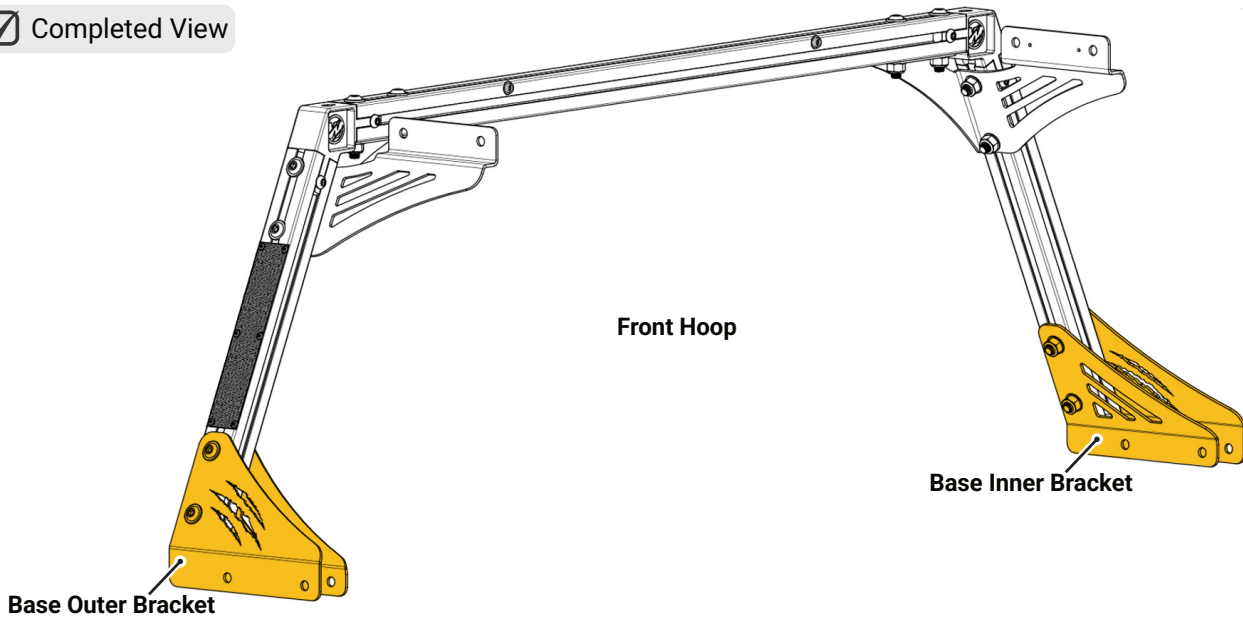

STEP 3.1 - Attach the Base Brackets with M10 Bolts, Washers and Nuts

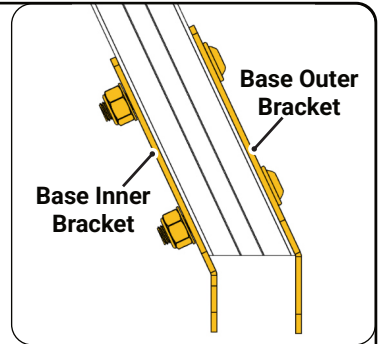
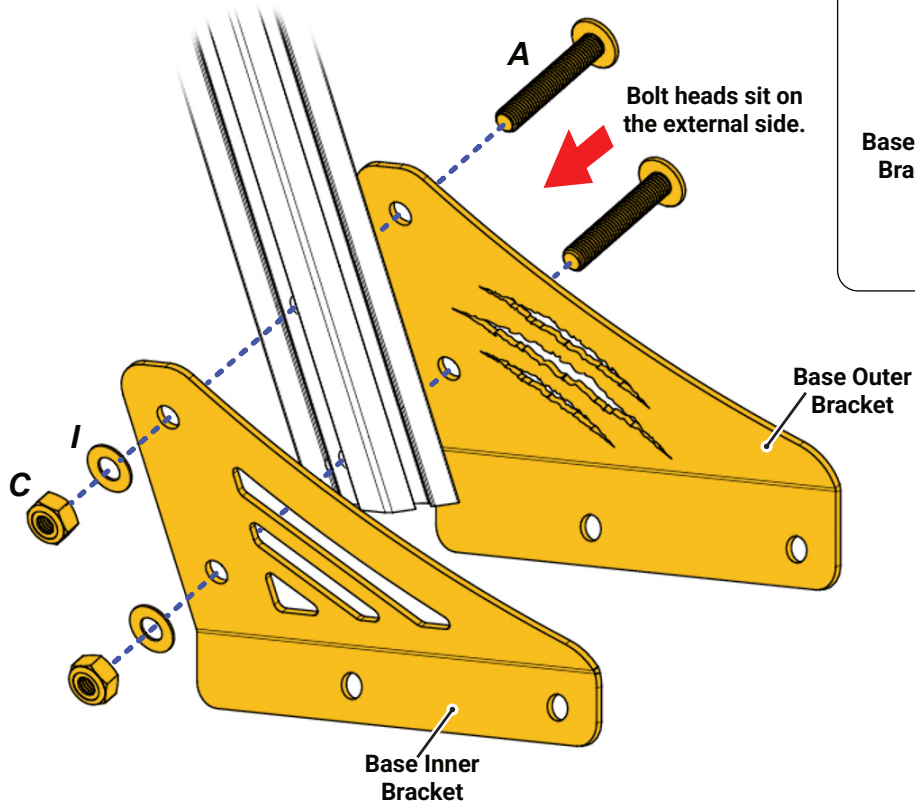

Using M10 Bolts attach the Base Outer Bracket to outside of the Angled Frame Leg and then attach the Base Inner Bracket to the inside of the Angled Frame Leg. Attach M10 Washers and Nuts to the M10 Bolts on the inside as shown. Repeat for other side. FINGER TIGHT ONLY at this stage as some flex is required in later steps.



Repeat for other side



Repeat all of Steps 1 to 3 again to make the Rear Hoop. They are identical parts that go on both ends of the truck bed (Front + Rear) and will require the same number of Hardware and same Tools.

STEP 4 - CONNECTING FRONT AND REAR HOOPS WITH TOP LONGITUDINAL RAILS

☑ Completed View

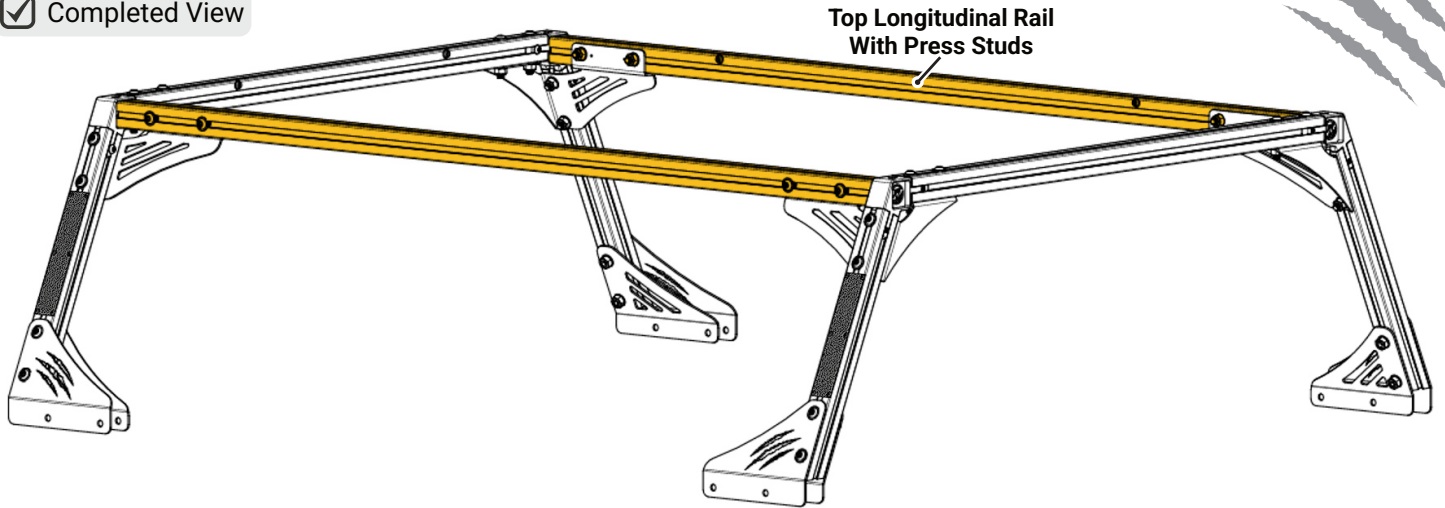

STEP 4.1 - Attach Top Longitudinal Rails with M10 Bolts, Washers and Nuts

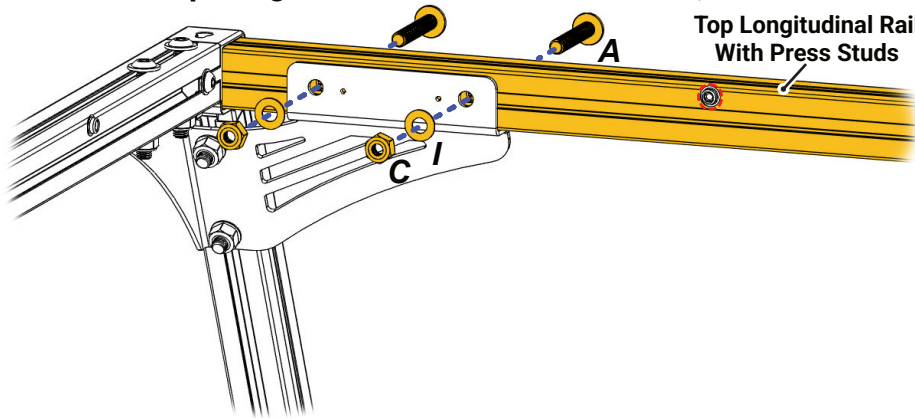

All press studs need to be on the top edge of the T-Slot and will face inwards towards the truck bed.

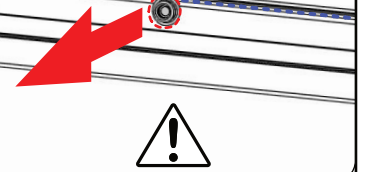

☞ Connect one side of the Top Longitudinal Rail with Press Studs to the Front Hoop by placing it into the Cast Corner and then resting it on the Top Bracket.

☞ Ensure the Press Studs on the Top Longitudinal Rails are on the top edge and will face inward towards the truck bed.

☞ Bolt using 2x M10 Bolts into the predrilled holes, adding M10 Washers and Nuts on the inside. Tighten. Repeat the step for the other side of the Front Hoop.

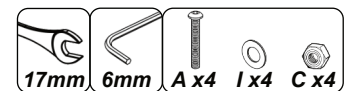

Repeat for other side



STEP 4.2 - Attach the Rear Hoop to rest of the Frame assembly



☞ Now connect the Rear Hoop to the ends of the Top Longitudinal Rails you just installed by following 'STEP 4.1' again for the Rear Hoop.

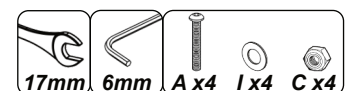

Repeat for other side



STEP 5 - ATTACH BASE LONGITUDINAL RAILS TO FRAME

☑ Completed View

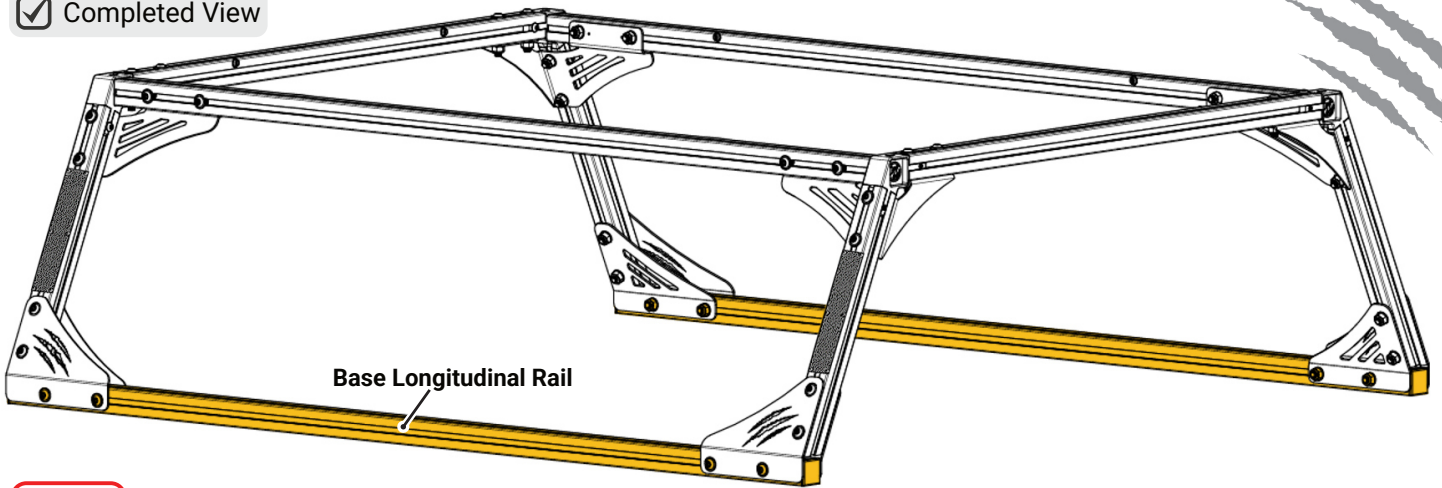

PRO TIP

For this part of the install, it's going to be easier to flip the frame on its end so it is resting on the floor and the other end is standing up closer to eye level. Placing the frame's end on a mat or cloth is recommended to prevent any scratches.

STEP 5.1 - Attach Base Longitudinal Rails to Frame with M10 Bolts, Washers and Nuts

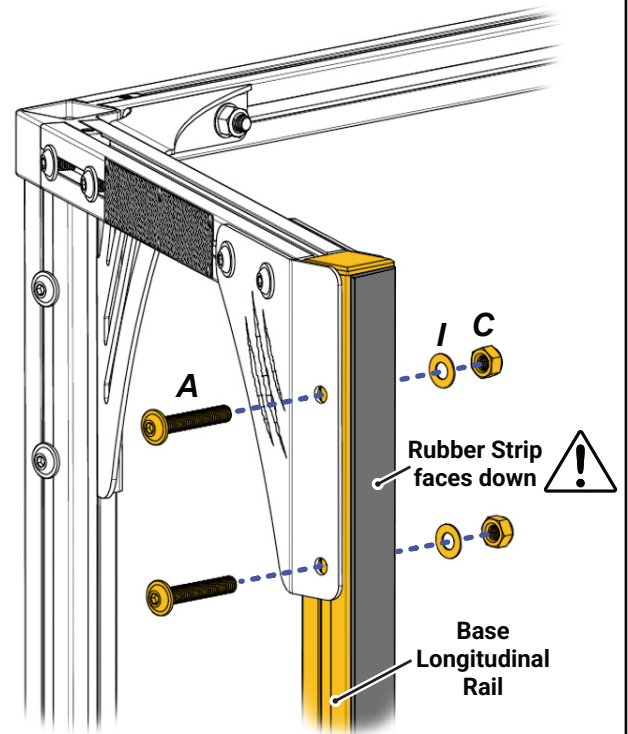

⚡ Making sure the Rubber Strip will face down, fit the Base Longitudinal Rail in between the Base Outer Bracket and Base Inner Bracket, bolting it in into the brackets using 2x M10 Bolts into the predrilled holes, adding M10 Washers and Nuts on the inside. Now get the second Base Longitudinal Rail and fit to the other side of the Hoops and bolt it in.

⚡ Now tighten all Bolts, including for all the Lower Brackets which attach to the Angled Frame Legs you left finger tight earlier in STEP 3.1.

You have now installed the Base Longitudinal Rails to the Frame as shown in STEP 5 'Completed View' image.

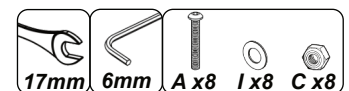

STEP 6 - ATTACH ROOF SUPPORT RODS

☑ Completed View

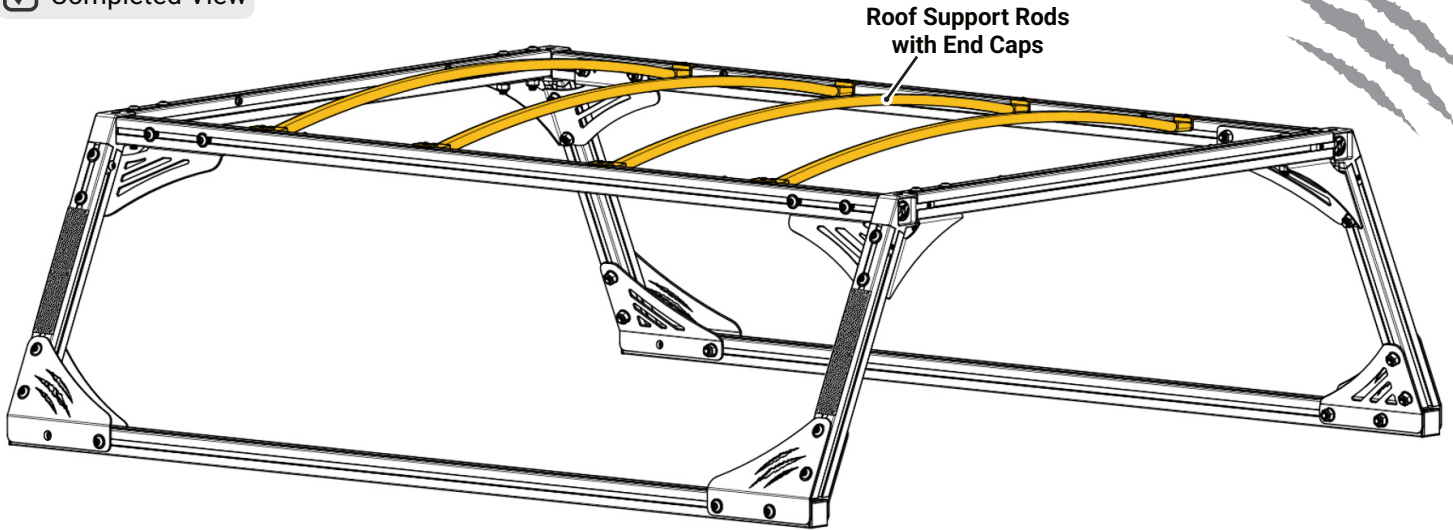

STEP 6.1 - Mark positions for the Self-Tapping Screws

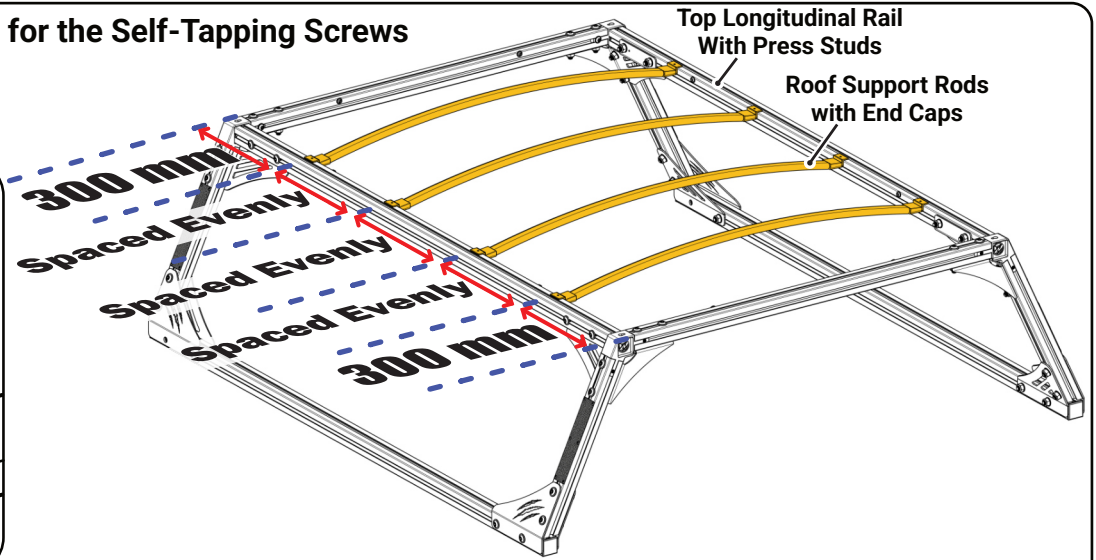
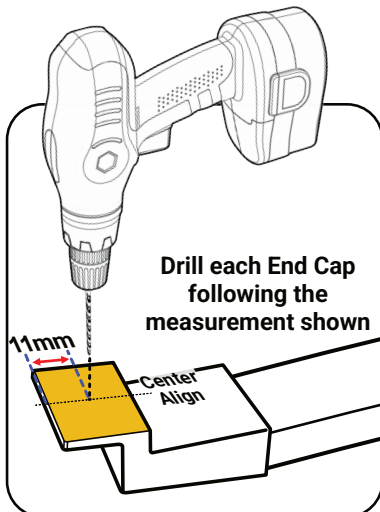

⌘ Drill plastic End Caps of the Roof Support Rods with the measurements shown.

⌘ Then place all four Roof Support Rods on the frame as above, following the placement measurements and mark the drill hole positions using the holes in the plastic End Caps of the Roof Support Rods.



STEP 6.2 - Screw in the Self-Tapping Screws into Roof Support Rod End Caps

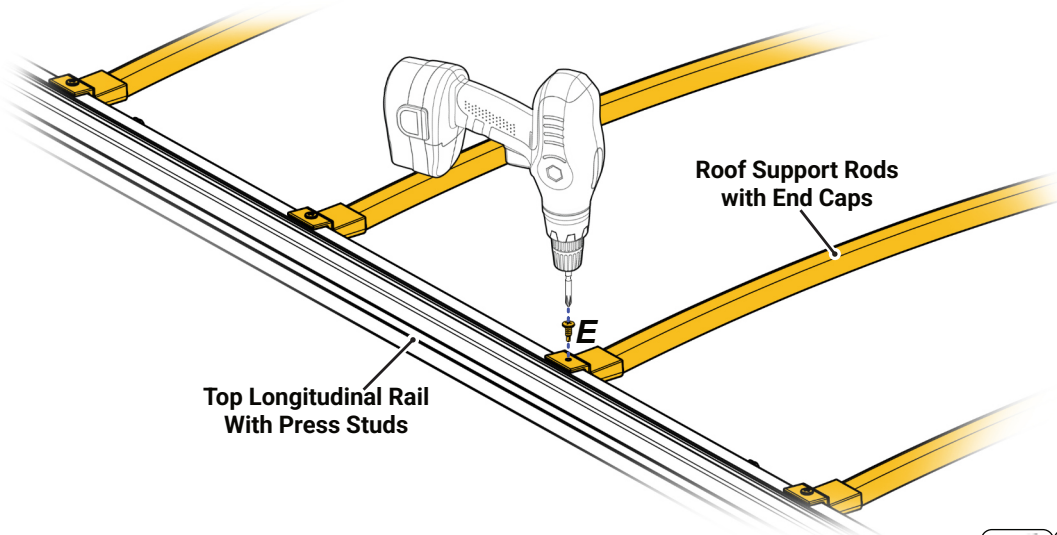

⌘ Use the Drill with Phillips Head No.2 Drill Bit to screw the Roof Support Rods into their marked positions with x8 Self-Tapping Screws, one for each plastic End Cap.

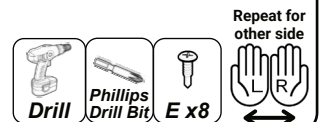

STEP 7 - PLACE FRAME ON THE TRUCK BED

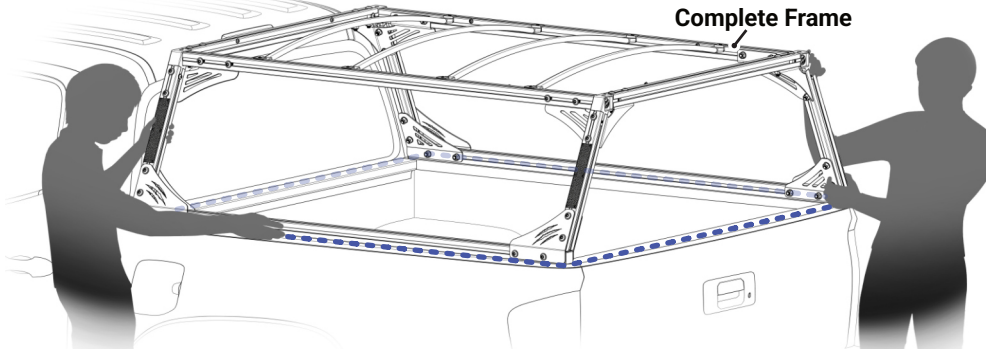

Using the assistance of a 2nd person, lift the frame and rest it carefully onto the top of the truck bed, keeping it roughly centre on the sides and front. At this point be careful that the frame isn't too close to an edge on either side, as if the frame falls, it could scratch the trucks paintwork. So make only small adjustments and have the 2nd person holding the frame steady whilst you do so. The 2nd person should also hold the frame until at least one side is bolted down.

Accurate frame placement is essential for correct canvas fitment: align the front end of the Base Longitudinal Rail exactly as shown in the truck model-specific illustration (STEP 7.1). Double-check both sides to confirm they are aligned identically. Make sure the frame doesn't move during the next steps.



STEP 7.1 - Position the Frame on the Truck Bed

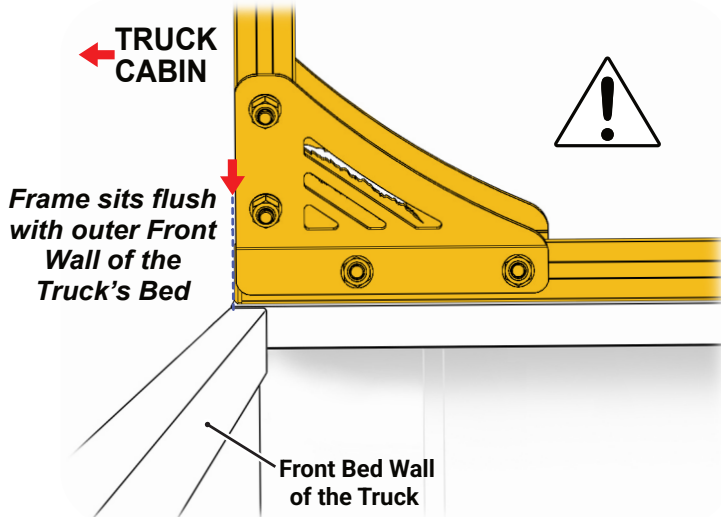

Using placement guide above, position Frame on the Truck's Bed. Align the Frame as guided, so that the Canvas Truck Cap will fit perfectly around the body of the Truck's bed.

STEP 7.2 - Securing the Frame to the Truck Bed using Clamps

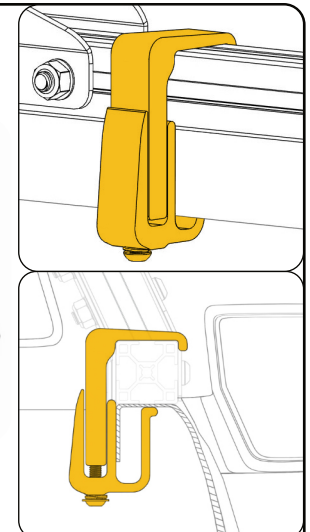
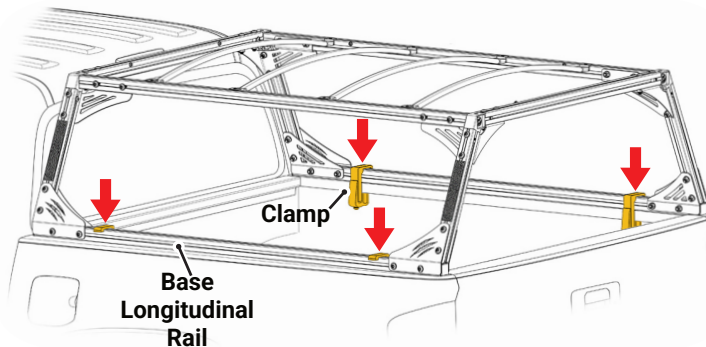
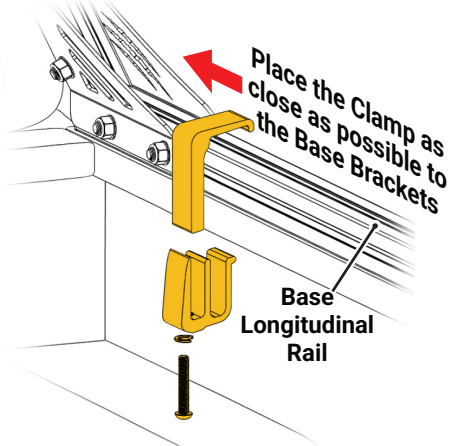

Starting with drivers side front inside of the bed, place the Clamp as close as possible to the Base Brackets, on the Base Longitudinal Rail. Tighten the M8 Bolt of the Clamp.

Repeat for Passenger Side Front Corner and then for both rear corners.

Note: Both front sides must be done before the rear, to ensure the frame remains aligned correctly as per previous step.

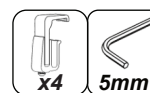

STEP 8 - FIT THE CANVAS TOP TO THE FRAME

☑ Completed View

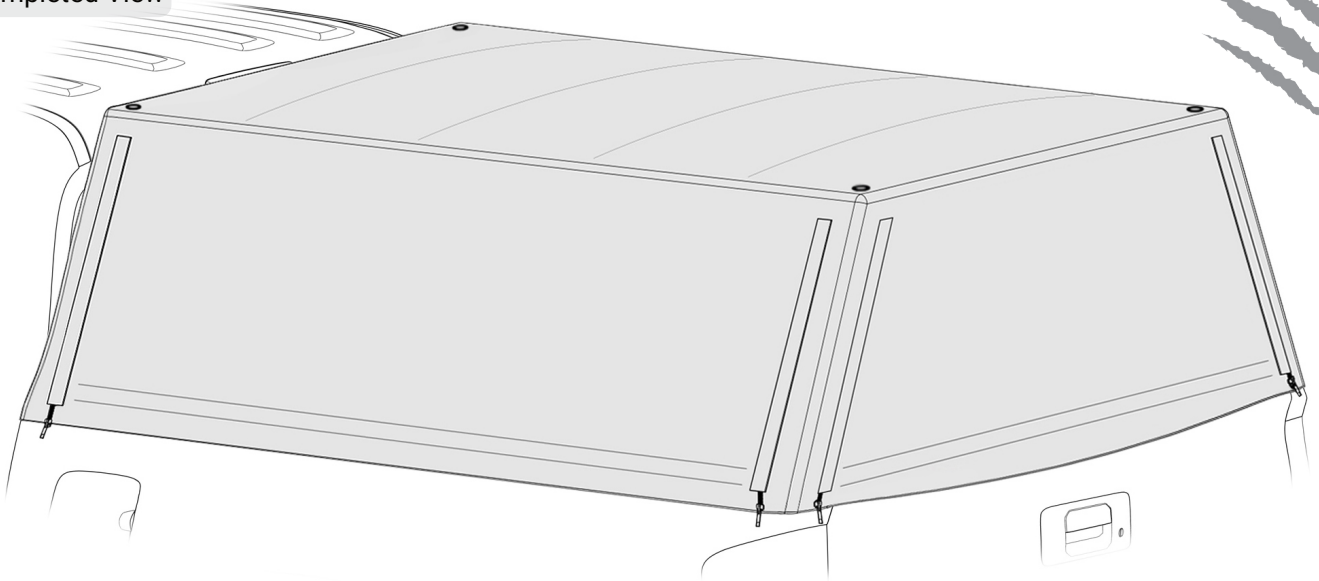

STEP 8.1 - Fitting and adjusting the Canvas Top on the Frame

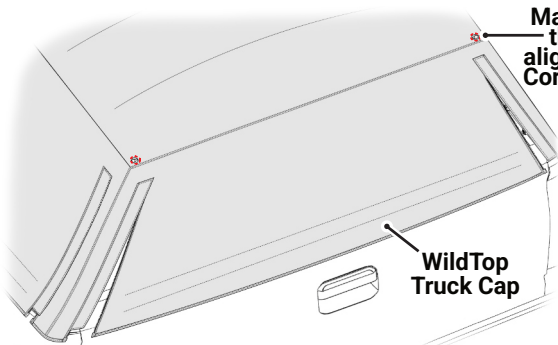

Make sure 4x holes in the roof of Canvas aligns with those in the Corner Rail Connectors

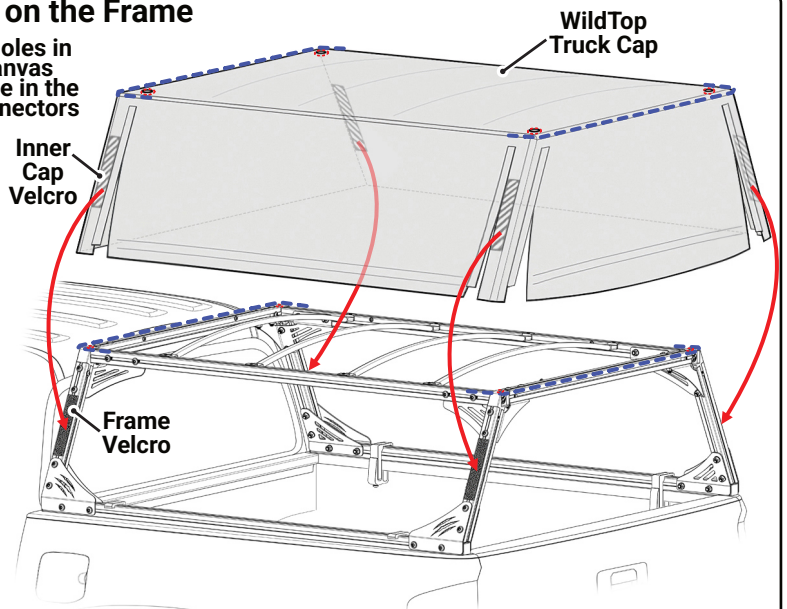

☞ Unfold the Truck Cap from the box and unzip all the zippers if they are closed. Open the Canvas completely and then drape over the frame. Ensure you put the front of the Canvas to the front of the frame. The zippers in the rear of the Canvas are at an angle and this identifies the rear or tailgate section of the Canvas. Adjust and make sure all the 4 corner Velcros align.

☞ Using a step ladder, ensure that the 4x holes in the roof of the WildTop Truck Cap are aligned with the holes which are in the Corner Rail Connectors.

STEP 8.2 - Attach the Velcro (Hook) to the Front of the Truck Bed and secure Front Velcro Panel

☞ Clean any dust or dirt from front edges of truck bed with clean cloth and then wipe down with Cleaning Wipe. Let the surface dry. Then apply the first Velcro (Hook) with even firm pressure.

☞ Repeat the same for the second Velcro. It goes on the top vertical front edge of the truck bed. It will help the cap to be stepped and folded down for firmer attachment to the truck's bed.

☞ From inside of the tub, pull the front Velcro Panel tightly and secure the Velcro sewn into the Canvas, to the Velcro installed on the Truck Bed. Ensure the Canvas is centred. The flap sits on the two Velcro (Hook) like a step.

☞ Allow both Velcro (Hook) to cure for 24 hours for full bond strength.

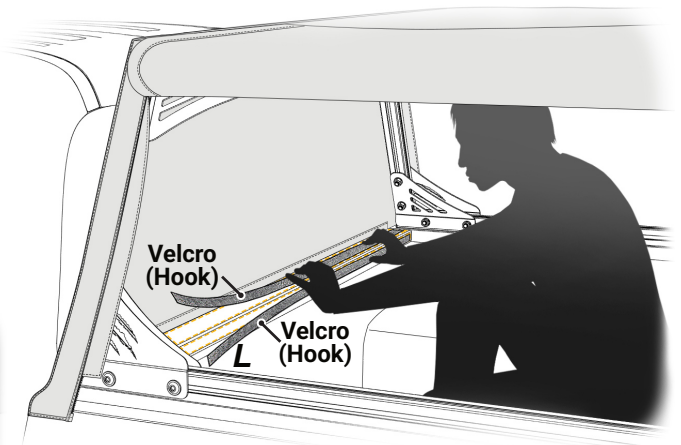
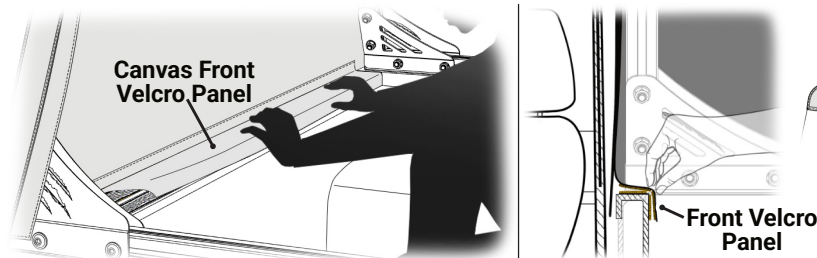

STEP 9 - INSTALL SIDE AND TAILGATE CANVAS TENSION RODS

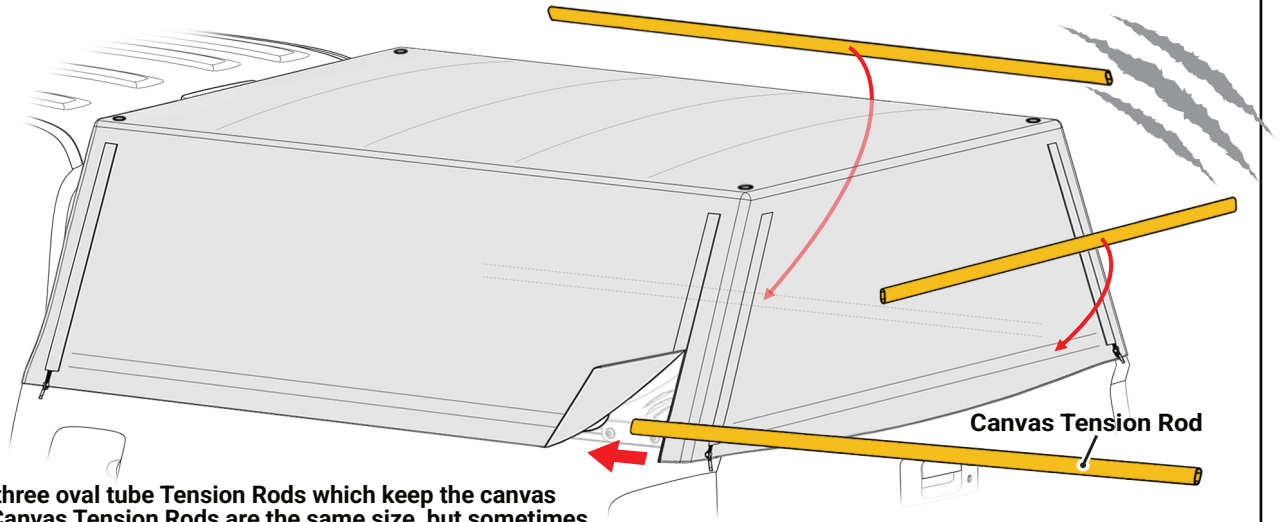

⚡ The Canvas has three oval tube Tension Rods which keep the canvas tight. The 2x Side Canvas Tension Rods are the same size, but sometimes the Tailgate Tension Rod is shorter.

⚡ Feed the tension rods into the pocket which is sewn onto the inside of the canvas as shown.

STEP 10 - INSTALL MAGNET STRAPS AND PAINT PROTECTION DISKS

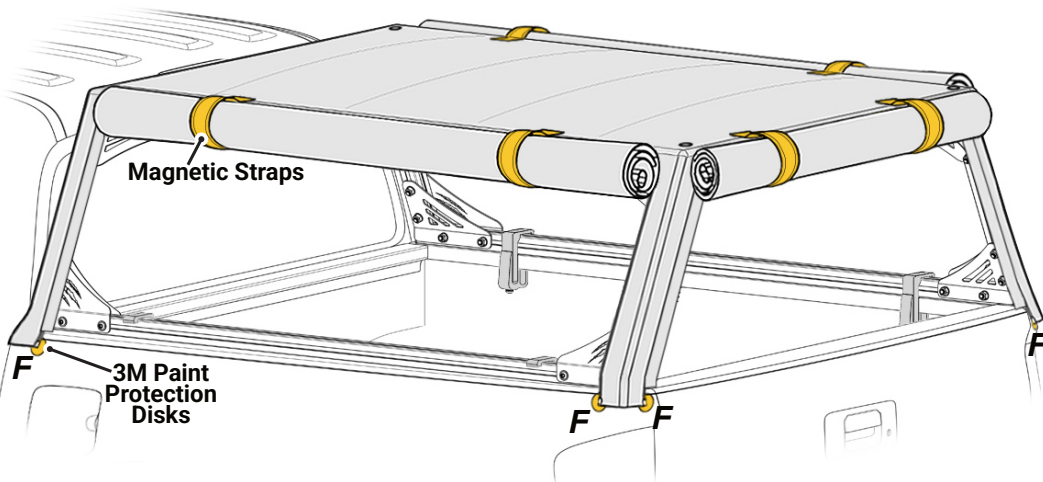

⚡ Clip on the Magnetic Straps by pushing the eyelet of the magnet strap into the press stud attached to the frame.

⚡ 3M Paint Protection Disks are supplied and these go behind the zipper sliders to protect the vehicle's paintwork. Clean the area thoroughly using Cleaning Wipe and then peel off the adhesive backing and place them behind each metal zipper head.

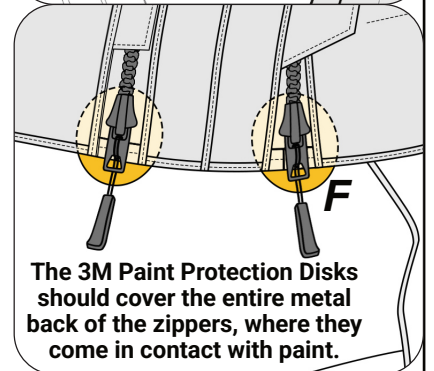
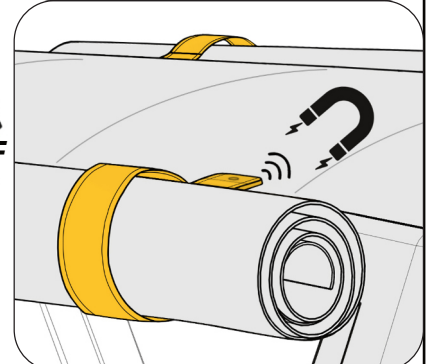
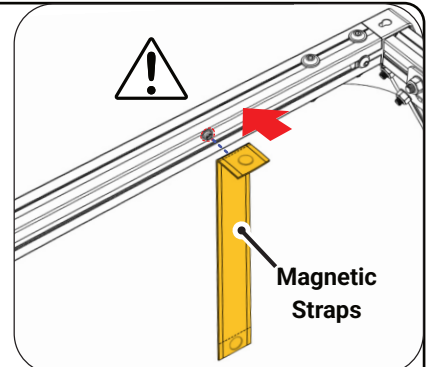

The 3M Paint Protection Disks should cover the entire metal back of the zippers, where they come in contact with paint.

NOTE - The Magnetic Straps must be installed correctly as wrong side of the magnet will not work. See illustration for this.

Repeat for other side

STEP 11 - INSTALL THE LADDER RACKS

☑ Completed View

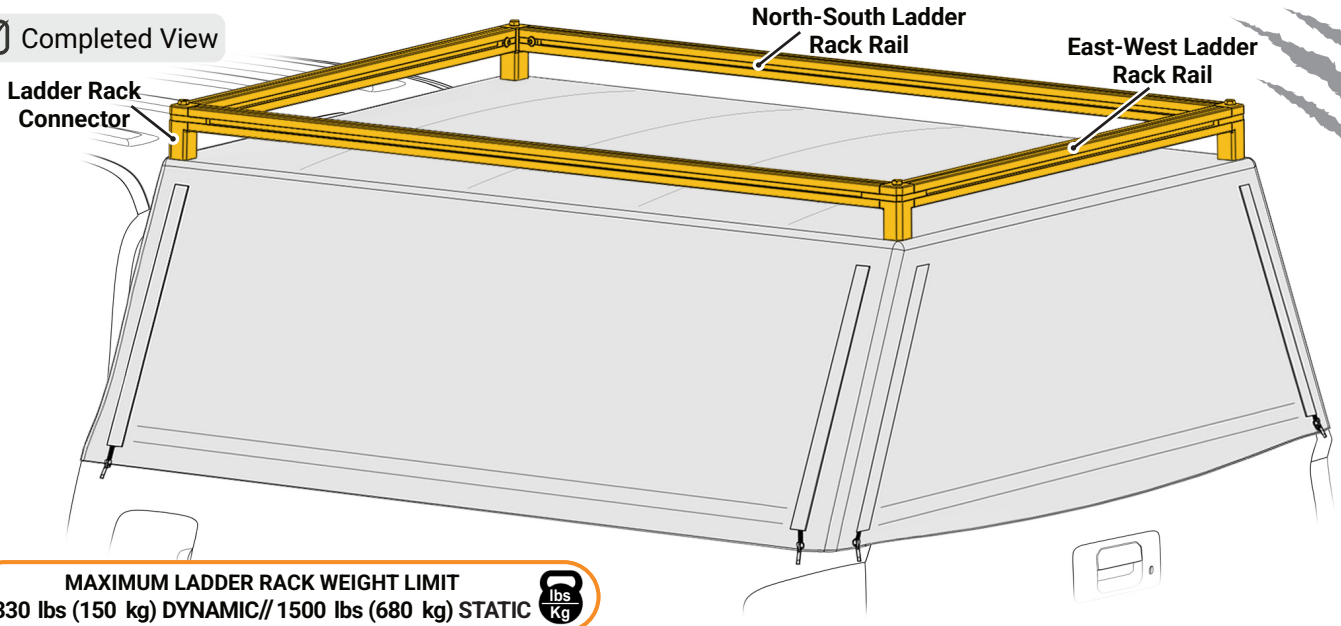

STEP 11.1 - Install all the Ladder Rack Parts

Starting at the Drivers Side Front Corner, place 1x Ladder Rack Connector with a Rubber Gasket on the bottom, and put an M10 Bolt with an M10 Fibre Washer through the Ladder Rack Connector and into the Corner Rail Connector.

Attach the M10 Nut on the inside, but do not tighten yet!

Install the East-West Ladder Rack into the fingers of the Ladder Rack Connector. Keep adding the Ladder Rack T-Slots and Ladder Rack Connectors until you have a complete frame, which connects back into the first Ladder Rack Connector you started with. Use the numbered order below as a guide to add the parts -

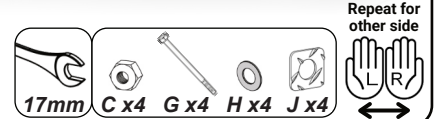
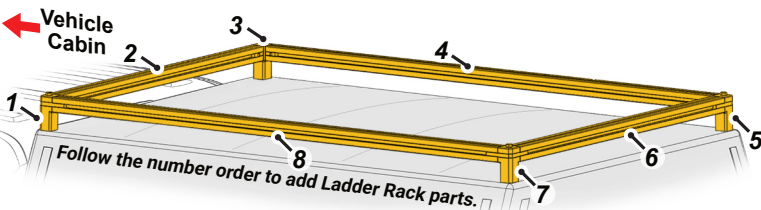
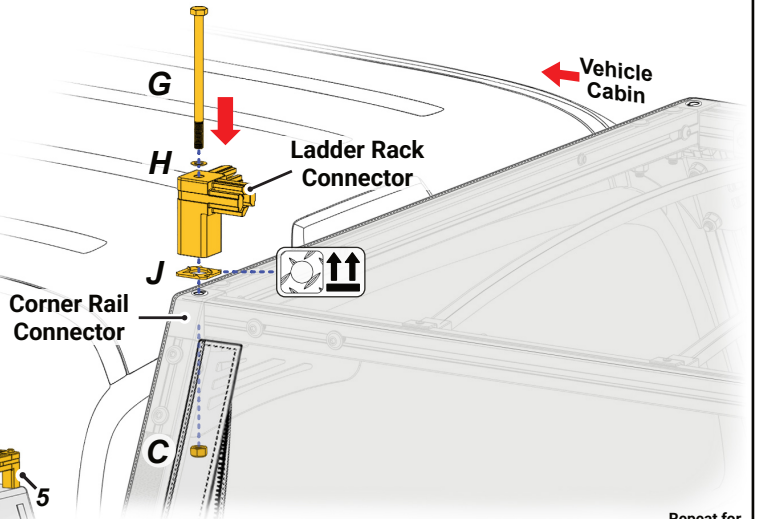

STEP 11.2 - Tighten up all the Ladder Rack Parts

Now tighten all the M10 Bolts and Nuts that were left untightened in previous step, starting with the drivers side front corner and then the passenger side rear Corner (diagonal) - this ensures it's square and aligned.

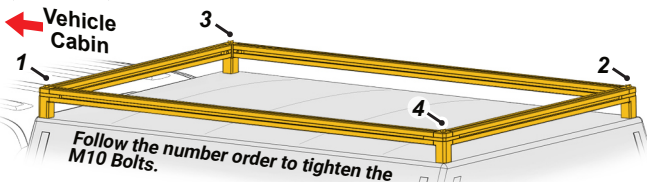

Next, fasten 2x M8 Bolts with 2x M8 Washer into the two inner fingers of each Ladder Rack Connector. These act as anti-rattle fasteners.

IMPORTANT TIP: This step is crucial to ensure waterproofing, as the Washers and Gaskets are specifically designed to prevent water ingress, so tightening them properly is important.

Make sure all the M10 Bolts and Nuts are tightened on all corners for waterproofing.

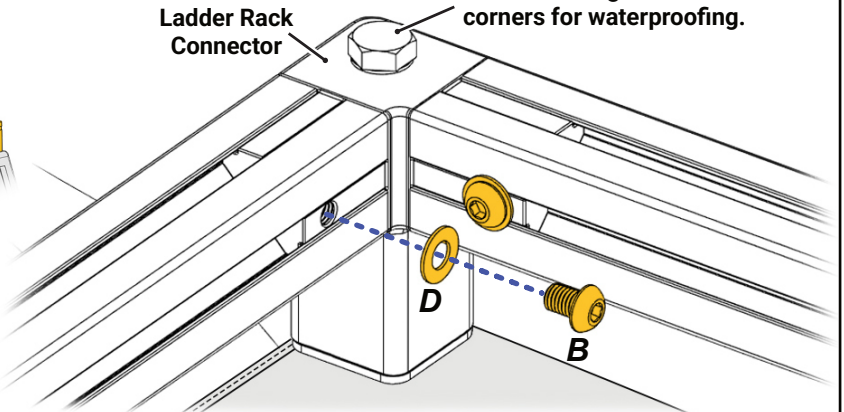

YOUR WILDTOP BEAST TRUCK CAP INSTALLTION IS NOW COMPLETE!

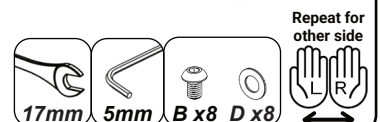



MAINTENANCE & CARE INSTRUCTIONS

Thank you for choosing a Wildtop truck cap for your vehicle! Our caps are built to last, providing you with the durability and functionality you need. However, to ensure the longevity of your truck cap, it is crucial that you follow these maintenance and care instructions carefully.

ZIPPERS

One key aspect of your truck cap maintenance involves the zippers. Dust or dirt may accumulate in the zipper teeth over time, especially if you are frequently in dusty or sandy environments. If such accumulation occurs, please avoid forcing the zipper open or closed, as it may cause damage. Instead, it is recommended that you wash the zipper teeth gently to remove any lodged debris. If the debris is stubborn, use a gentle brush. Dry zippers after.

CANVAS

The premium canvas of your truck cap also requires special care to maintain its physical performance and aesthetic lustre. In particular, the waterproof performance of the canvas can be improved through proper conditioning. To condition the canvas, start by fitting the cap to your truck. Then thoroughly wet the canvas with a garden hose, making sure to cover both the inside and the outside. Allow the cap to fully dry, preferably in the sun. Repeat 2 or 3 more times. This allows the fabric to settle after transport and packaging.

The following key points will help maximise the durability and life of your canvas:

- /// To remove dirt, brush the fabric with a soft bristle brush. An occasional hosing may remove dust and some ingrained dirt.
- /// Never scrub the canvas fabric.
- /// Do not expose to petrol or oil.
- /// Immediately remove deposits of organic matter (such as soil, grass, bird droppings).
- /// Remove any mildew, as it appears, first by brushing, then by treating with diluted chlorine bleach (typically 1 part household grade bleach to 4 parts water to achieve 1% available chlorine). Allow to dry in the sun, then hose well to remove any residue.
- /// Do not use strong bleach such as 'pool chlorine'.
- /// Do not use soaps, detergents, solvents, or other liquid cleaners.

By following these instructions, you can extend the life of your soft truck cap, maintain its aesthetic appeal, and enhance its functional performance. We want your experience with our product to be nothing short of exceptional, and your care in maintaining your truck cap is a significant part of that. Thank you for your cooperation and enjoy your Wildtop truck cap!



Send us a photo of your WildTop!
Happy with how your truck top turned out?
Please send us a photo to: info@wild-top.com



IMPORTANT INFORMATION

Safety

- Ensure the truck cap is completely closed before driving.
- Regularly check the tightness of the fasteners.
- Load must be evenly distributed on Ladder Racks and adequately secured.
- DO NOT EXCEED 330 lbs (150 kg) Dynamic and 1500 lbs (680 kg) Static weight limit on Ladder Racks.**

Load Carrying Requirements and Recommendations

- Weight limits have been tested on the truck cap frame itself, distributed evenly across ladder racks. This does not mean the vehicle bed is capable of such weights. Consult your vehicle manufacturer for further details.
- The load must be evenly distributed over the area of the Ladder Rack system, and the center of gravity of the load kept as low as possible. Loads which overhang the ends of the carrier system must conform to any relevant laws or by-laws in your area, and shall be adequately secured.
- Loads must be adequately secured using suitable straps or similar tightening and locking devices. The security of the load and roof load carrier shall be checked after loading and regularly throughout the journey. Elastic straps must not be used. The user is warned to maintain and to use straps in working order.
- It is recommended that items which may produce significant lifting forces (surfboard, sailboard, etc) are not carried side-by-side, but in such a way that lifting force is minimized, securing them independently to the front and rear of the vehicle using straps or other methods which are capable of withstanding the lifting forces. Elastic straps must not be used. Where specialized accessories are available to carry or secure loads, it is recommended that they are used.
- The handling characteristics of a vehicle (in particular crosswind sensitivity, handling on bends and braking) change when a carrier system is fitted and especially if that system is loaded. Driving techniques should be altered to allow for these changes, speed reduced, especially on bends, and braking distances made greater.

