

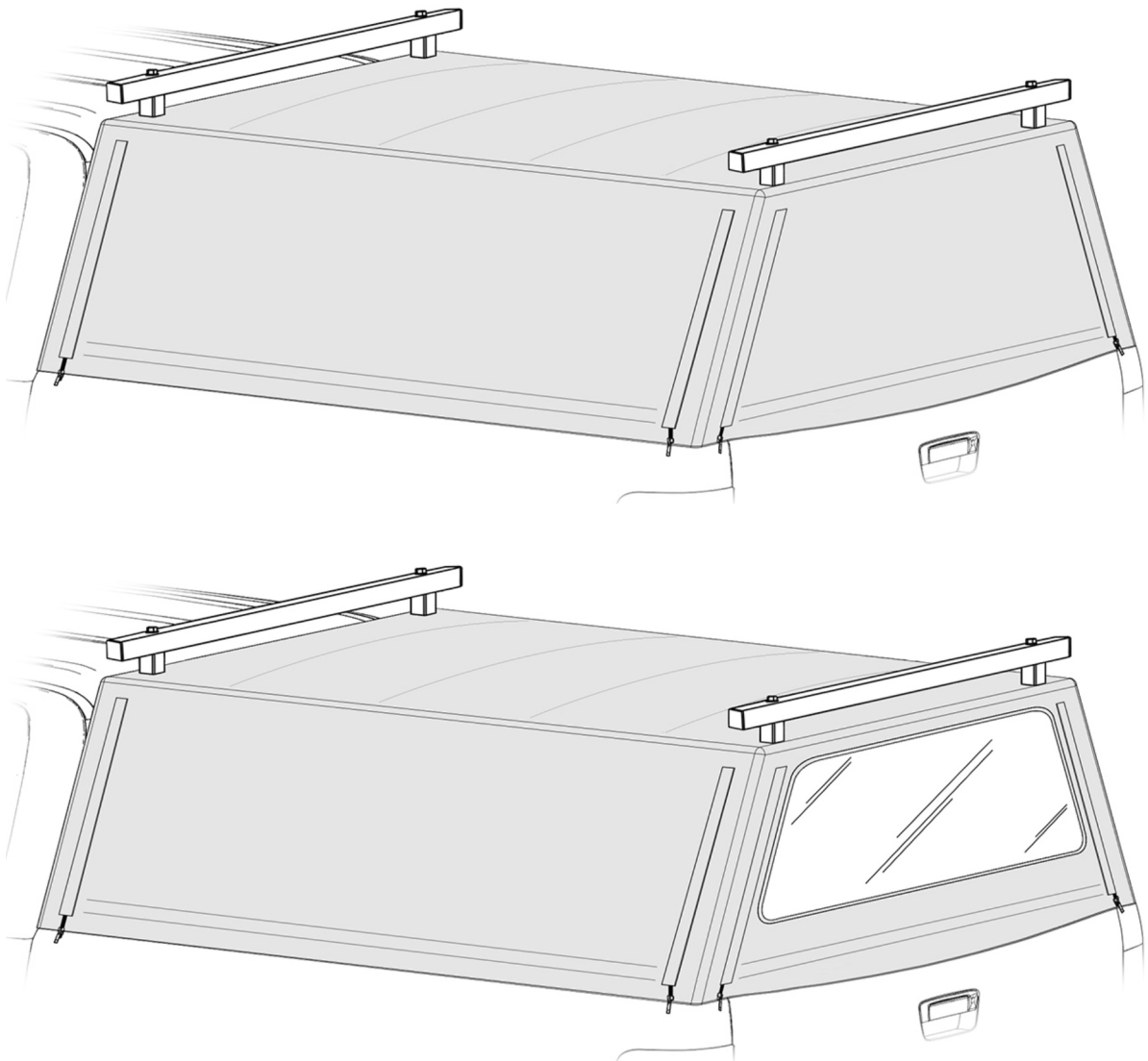

WILDTOP **NOMAD**















TRUCK CAP INSTALLATION GUIDE

SUPPLIED HARDWARE

Note: Our kits are standardized to minimize packing errors. Some additional hardware may be included.



												L-Bracket models only		
(A)	(B)	(C)	(D)	(E)	(F)	(G)	(H)	(I)	(J)	(K)	(L)	(M)	(N)	(O)
M10 x 60mm Bolt	M10 Nut	M10 Washer	12mm Self-Tapping Screw	M10 x 150mm Hex Bolt	M10 Red Fibre Washer	Ladder Rack Spacer	Rubber Gasket	Cleaning Wipe	Velcro (Hook)	3M Paint Protection Disk	3M Adhesive Primer Stick	M8 x 20mm Cap Screw	M8 Washer	M8 Rectangle Nut
36 pcs	40 pcs	40 pcs	10 pcs	4 pcs	8 pcs	4 pcs	4 pcs	2 pcs	2 pcs	6 pcs	1 pc	16 pcs	16 pcs	8 pcs

WHAT'S IN THE BOX

(P) - 2 x Short Top Rails (With press studs)



(P) - 4 x Angled Legs



(Q) - 2 x Long Top Rails (With press studs)



(R) - 4 x Corner Connectors

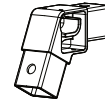

(S) - 2 x Bottom Rails



(T) - 4 x Outer Brackets (2 Left, 2 Right)

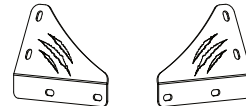

(U) - 4 x Inner Brackets (2 Left, 2 Right)

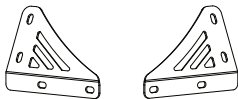

(V) - 4 x Upper Brackets (2 Left, 2 Right)

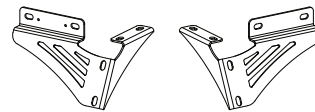

(W) - 4 x Roof Support Bars



(X) - 4 x Clamps **OR** **(Y)** - 4 x L-Brackets



(Z) - 2 x Ladder Racks



(AA) - 3 x Tension Rods



(AB) - 6 or 8 x Magnet Straps



(AC) - 1 x Canvas Cover



TOOLS REQUIRED



Drill



#2 Phillips Bit



4mm Drill Bit

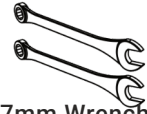

17mm Wrench x2

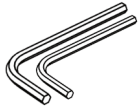

6mm Hex Key

5mm Hex Key (Clamp-on models only)



Marker

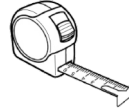

Tape Measure



Clean Cloth

ADDITIONAL TOOLS REQUIRED - MODEL SPECIFIC

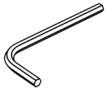

4mm Hex Key

(Honda Ridgeline and
Jeep Gladiator)

SAFETY & PRECAUTION



- ⚠️ Ensure vehicle is parked on level ground before installation.
- ⚠️ During the accessory fitment, ensure all American automotive and dealership practices are followed.
- ⚠️ Always refer to the vehicle's workshop manual when removing components.
- ⚠️ Do not use power tools for the nuts and bolts during the assembly process to prevent overtightening or damaging components.
- ⚠️ Grease should be used on bolts to prevent galling.
- ⚠️ Ensure that appropriate Personal Protective Equipment is used.



1 - ATTACH THE VELCRO TO THE TRUCK BED

 Ford Maverick and Honda Ridgeline models will have the Velcro attach to the Front Rail instead of the vehicle bed. If you have either of these vehicles, skip Step 1 for now as you will be directed to return to this step later.

STEP 1.1 - Apply the Velcro primer to the truck bed

 **VERY IMPORTANT**
Clean any dust or debris from the top front edges of the truck bed with a clean cloth and then wipe down with one of the provided Surface Cleaning Wipes  (you will need the second one later). Let the surface dry.

Apply a thin layer of 3M Primer  to the areas where the Velcro will attach (see illustration below). To do this, crush the primer stick until the internal glass vial breaks. Then apply the primer to the surface with the felt tip and allow it to become tacky (approximately 2-5 minutes) before applying the Velcro Strips.

STEP 1.2 - Attach the Velcro Strips to the truck bed

The first Velcro Strip  is adhered to the top front edge of the truck bed. The Second is adhered to the vertical front edge of the truck bed, just below the first strip.

To ensure full bond strength, firmly press the Velcro Strip  onto the surface firmly and allow the adhesive to cure for 24 hours before use.

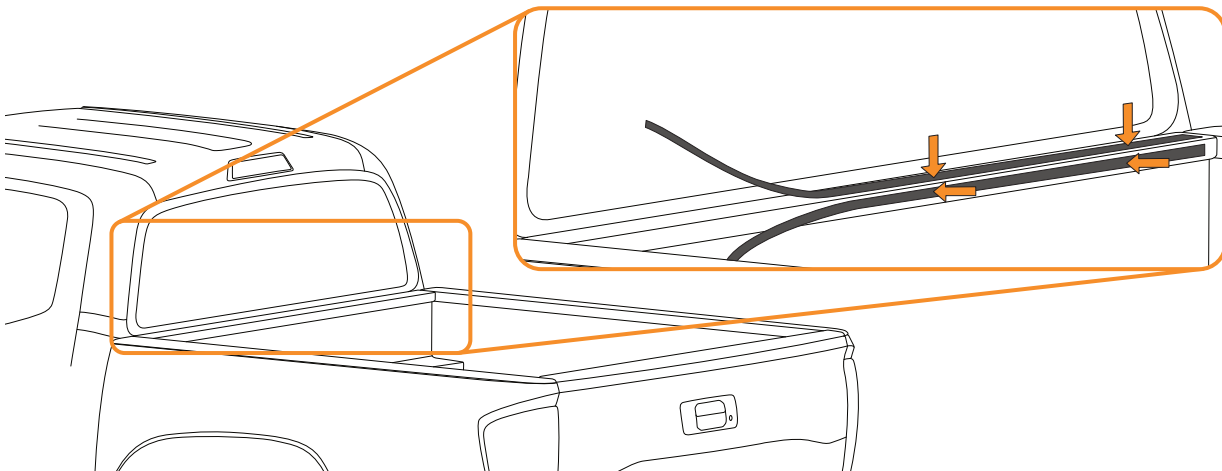

STEP 2 - ASSEMBLE TWO FRAME HOOPS

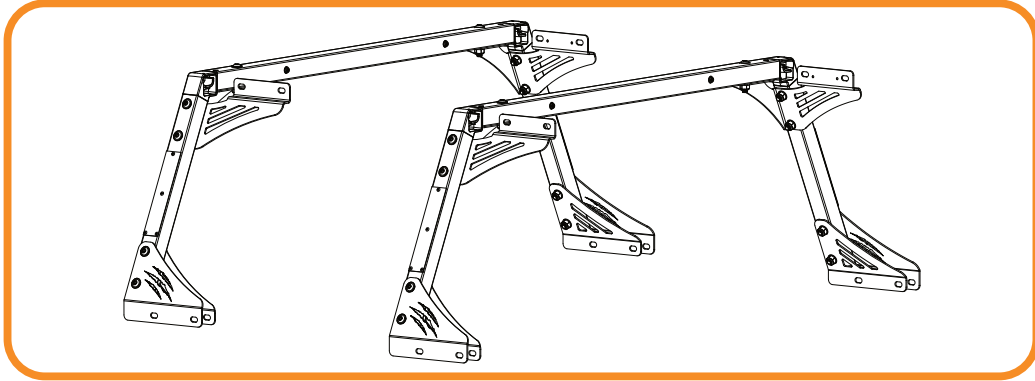

STEP 2.1 - Put Corner Connectors into each end of the Short Top Rail

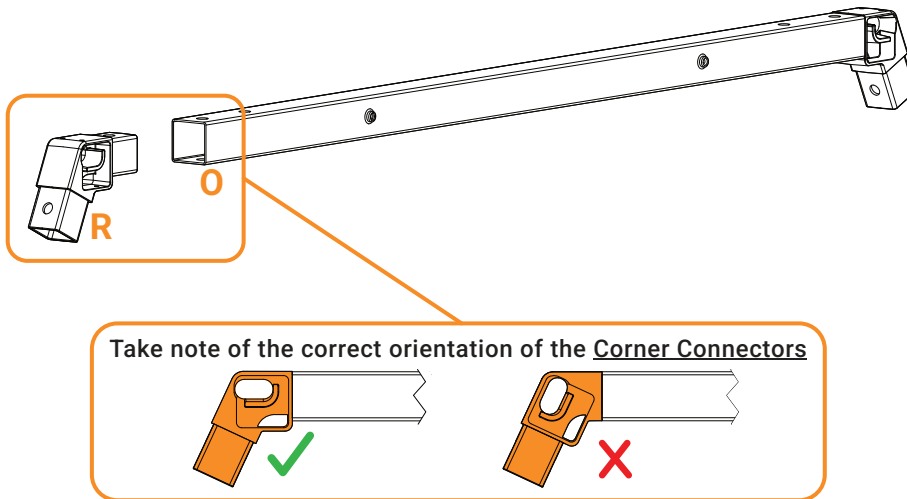

STEP 2.2 - Attach the Angled Legs to the Corner Connectors

With the Velcro facing out, attach the Angled Leg **P** to the other end of the Corner Connector **R**.

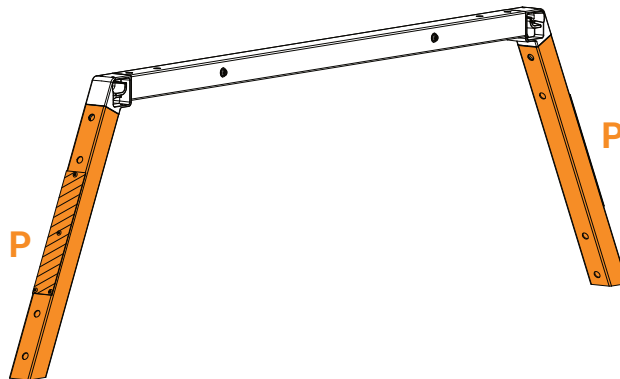

STEP 2.3 - Attach the Upper Brackets

Using only 3 of the 4 bolt holes, attach the Upper Bracket (V) to the Frame Hoop as illustrated. The remaining hole on the Short Top Rail (O) will be used to install the Ladder Rack in a later step. Ensure the Press Studs are facing the same direction as illustrated. Repeat for the other side of the Frame Hoop.

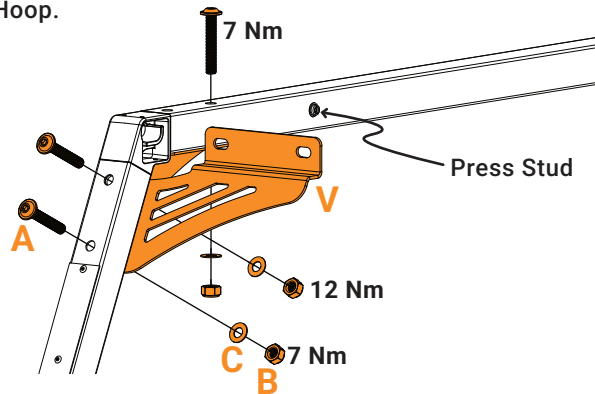

STEP 2.4 - Attach Inner and Outer Brackets

Attach the Inner Bracket (U) and Outer Bracket (T) to the bottom of the Angled Leg (P). For this step, do not fully tighten the bolts just yet as we will need the brackets to be loose for a later step. Repeat for the other side of the Frame Hoop.

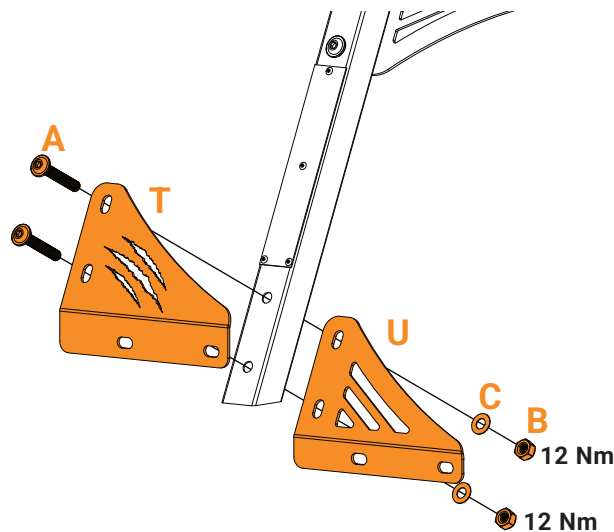

STEP 2.5 - Repeat 2.1 to 2.4 to make the second Frame Hoop

After this step, you should have two identical "Frame Hoops" as illustrated below.

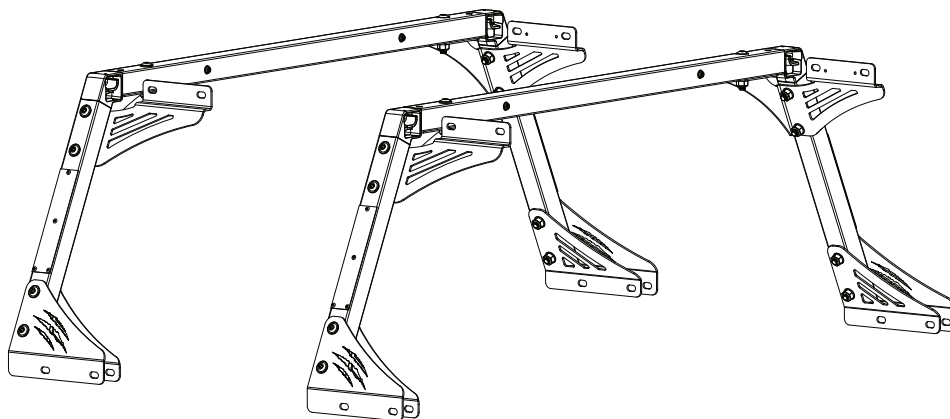

STEP 3 - ATTACH THE LONG TOP RAILS

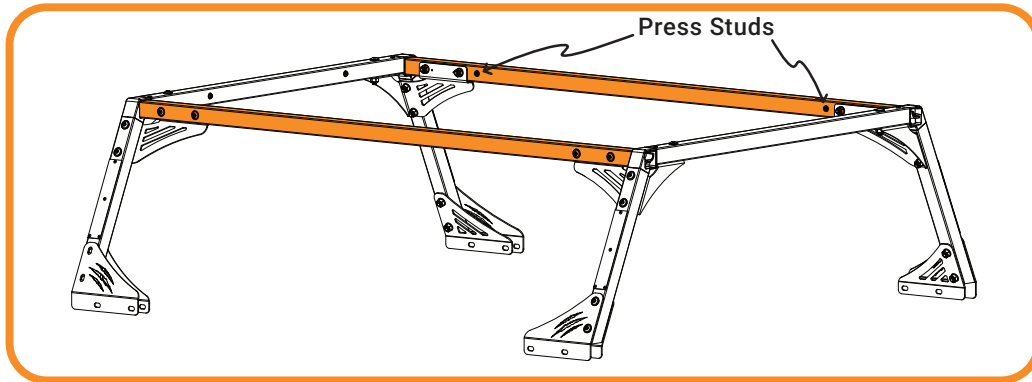

STEP 3.1 - Bolt the Long Top Rails into the Upper Brackets

Insert the Long Top Rail (Q) into the Corner Connector (R), making sure the press studs on these Long Top Rails (Q) are facing inwards as illustrated above.

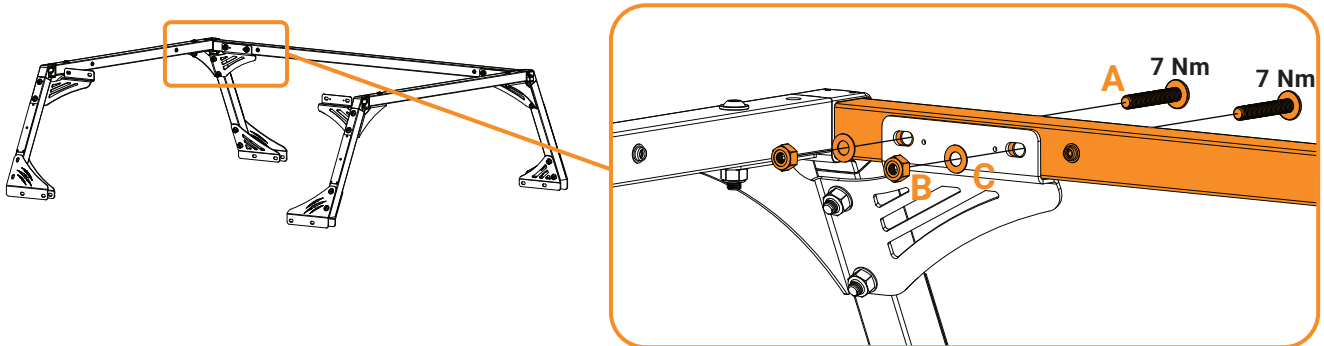

IMPORTANT NOTE: Make sure the Bolt holes in the Long Top Rails (Q) align with the center of the slotted holes in the Upper Bracket (V) as illustrated. If they are not aligned, the cover may not fit the frame.

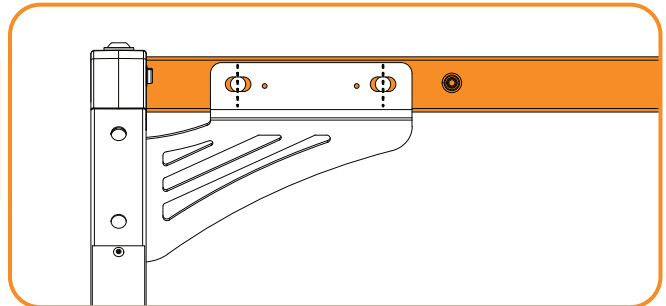

STEP 3.2 - Repeat for all four corners

After attaching both Long Top Rails (Q) and bolting into the each Upper Bracket (V), you should have a frame like the one illustrated at the top of this page.

STEP 4 - ATTACH THE BOTTOM RAILS

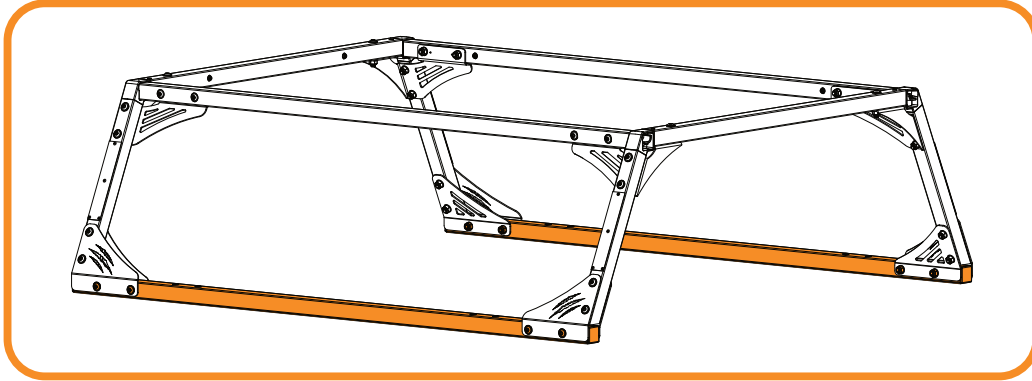

STEP 4.1 - Bolt the Bottom Rails to the Brackets

Bolt the Bottom Rail (S) to the Inner Brackets (U) and Outer Brackets (T).

Some vehicle models use Clamps (X) while others may use L-Brackets (Y). So choose the option below that best suits your vehicle.

You can now tighten the bolts we left loose in Step 2.4



Ford Maverick and Honda Ridgeline Models have an additional step here. See Appendix for instructions before proceeding.

L-Bracket Models

Ensure Rivet Nuts are on the top face

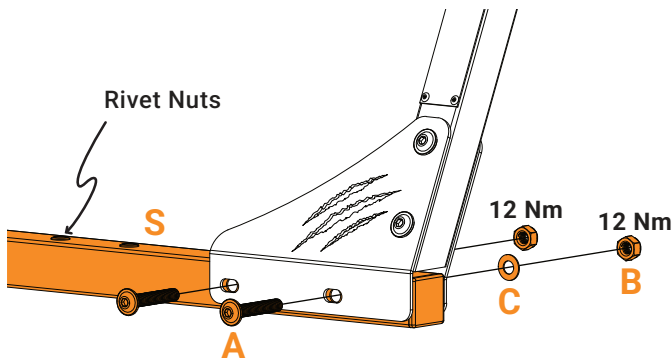

OR

Clamp-On Models

Ensure Rubber is on the bottom face

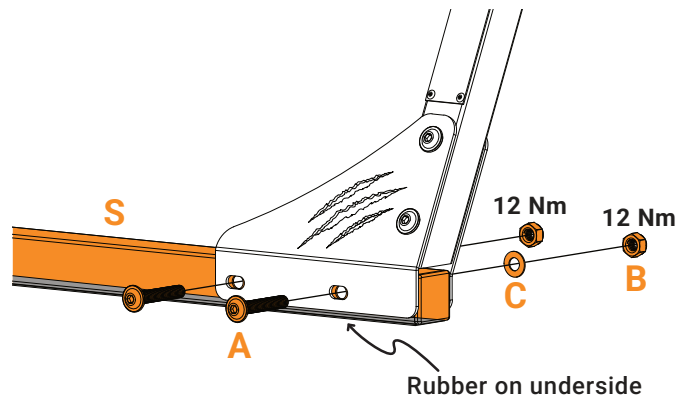

IMPORTANT NOTE: Make sure the bolt holes in the Bottom Rail (S) align with the center of the slotted holes in the Outer Bracket (T) as illustrated. If they are not aligned, the cover may not fit the frame.

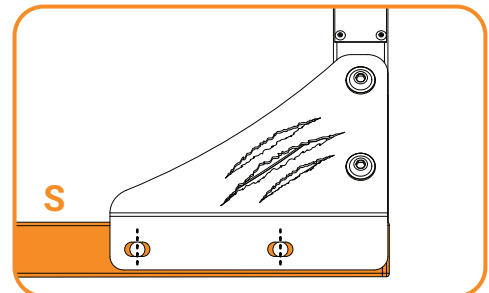

STEP 4.2 - Repeat for all four corners

Continue bolting the Bottom Rails (S) to each Inner Bracket (U) and Outer Bracket (T)

Once both Bottom Rails (S) are connected, you should have a frame like the one illustrated at the top of this page.

STEP 5 - ATTACH THE ROOF SUPPORT BARS

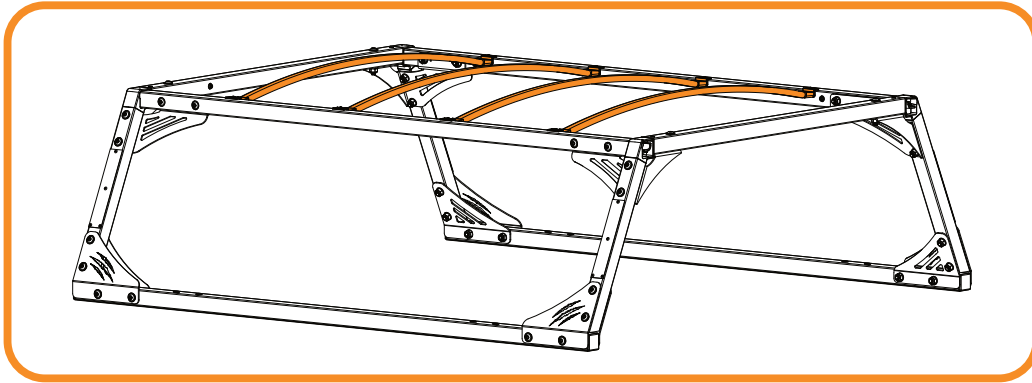

STEP 5.1 - Measure and mark the positions for the Roof Support Bars

On each Long Top Rail **Q**, mark the four mounting points for the Roof Support Bars **W**.

Make the first two marks 1 foot in from each end of the frame, then mark the remaining two points spaced evenly between them.

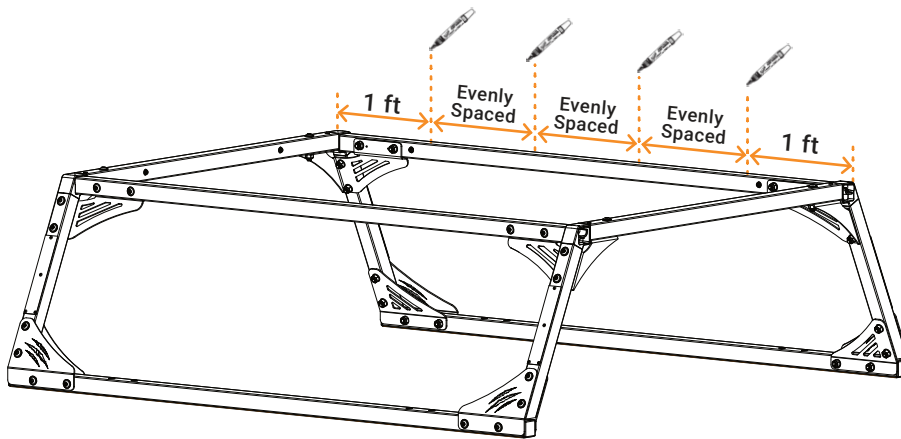

STEP 5.2 - Attach the Roof Support Bars using the Self-Tapping Screws

Pre-drill the plastic end caps to make the Self-Tapping Screws **D** easier to use. Then align the Roof Support Bars **W** with the marks made in the previous step and screw them into place with the Drill and #2 Phillips Bit.

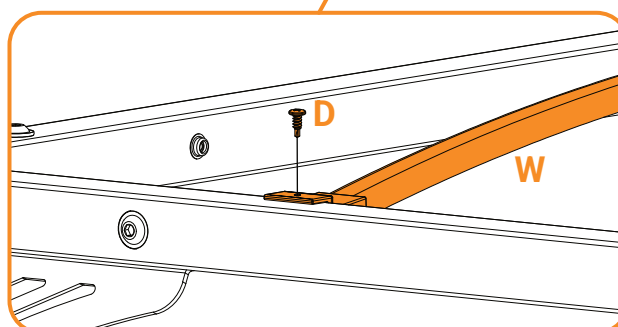
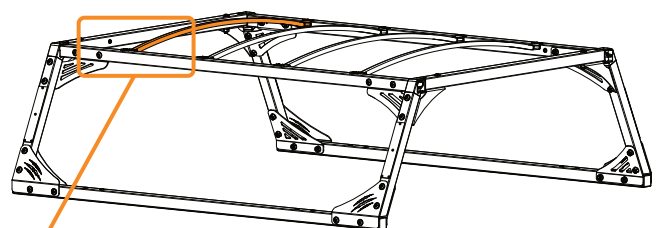
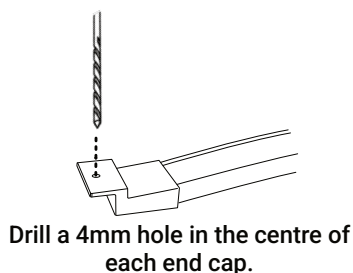

STEP 6 - FITTING THE COVER

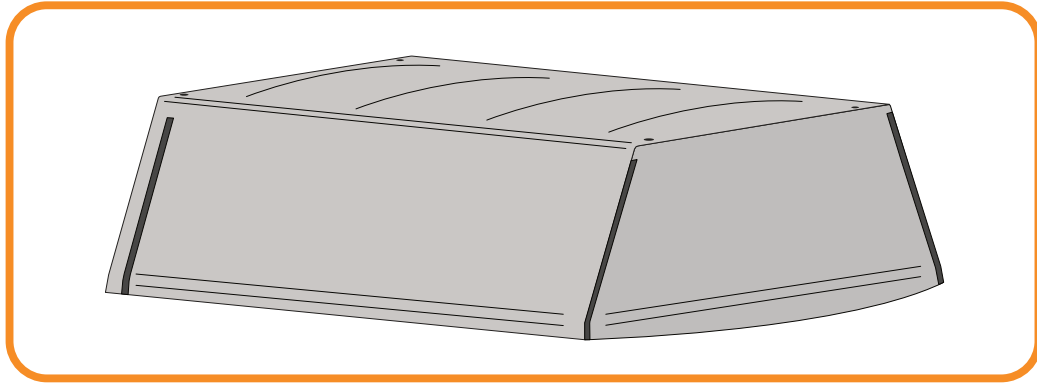

STEP 6.1- Attach the Magnet Straps

Press the Magnet Straps **AB** onto the press studs on the Frame. There should be 2 on each of the Long Top Rails **Q** and 2 on one of the Short Top Rails **O** (This will be the rear of the vehicle).

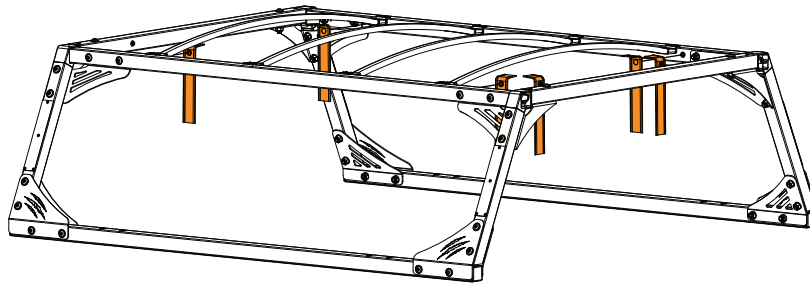

STEP 6.2- Fit the Cover to the Frame

Unzip all the zips then drape the Cover over the Frame and attach to the Velcro sections in each corner while ensuring the holes in the roof line up with the ladder rack holes in the frame.

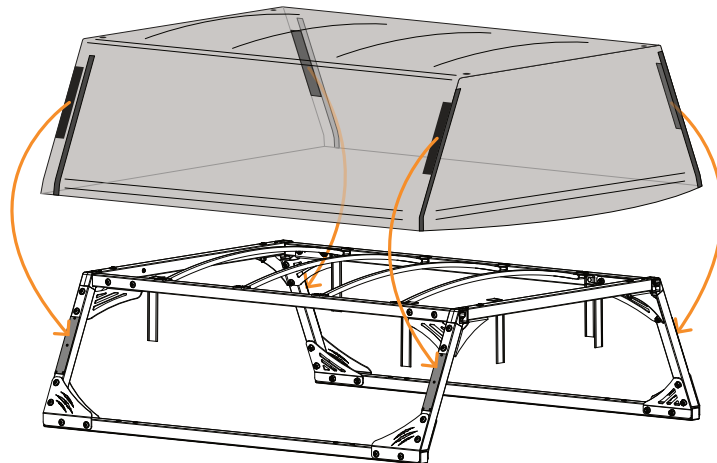

STEP 6.3- Install Tension Rods

Insert the Tension Rods **AA** into each of the three pockets inside the Cover. If one of the Tension Rods is shorter than the others, it belongs in the Rear Tailgate Pocket.

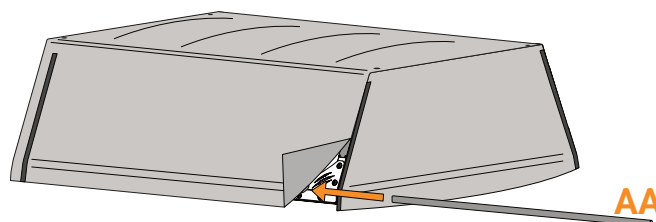

STEP 7 - INSTALL THE LADDER RACKS

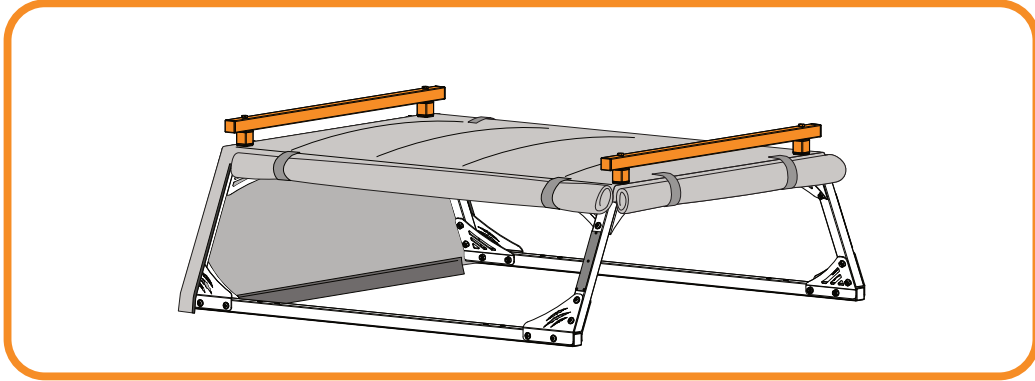

STEP 7.1 - Roll up the cover side panels

The next few steps will require access to the inside of the topper. Roll up the cover panels and fix into place with the Magnet Straps (AB) to allow for easier access.

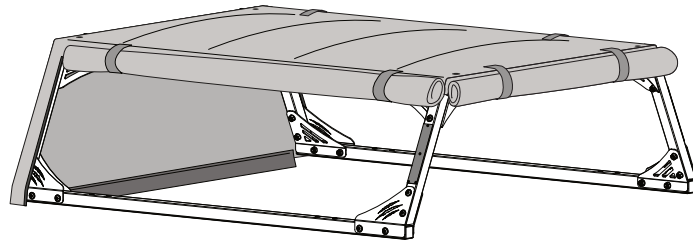

STEP 7.2 - Install the Ladder Racks and Spacers

Install all the Ladder Rack (Z) assembly as illustrated. Make sure the holes in the canvas are completely sealed by the Rubber Gaskets (H).

The ribbed side of the Rubber Gaskets (H) should face up.

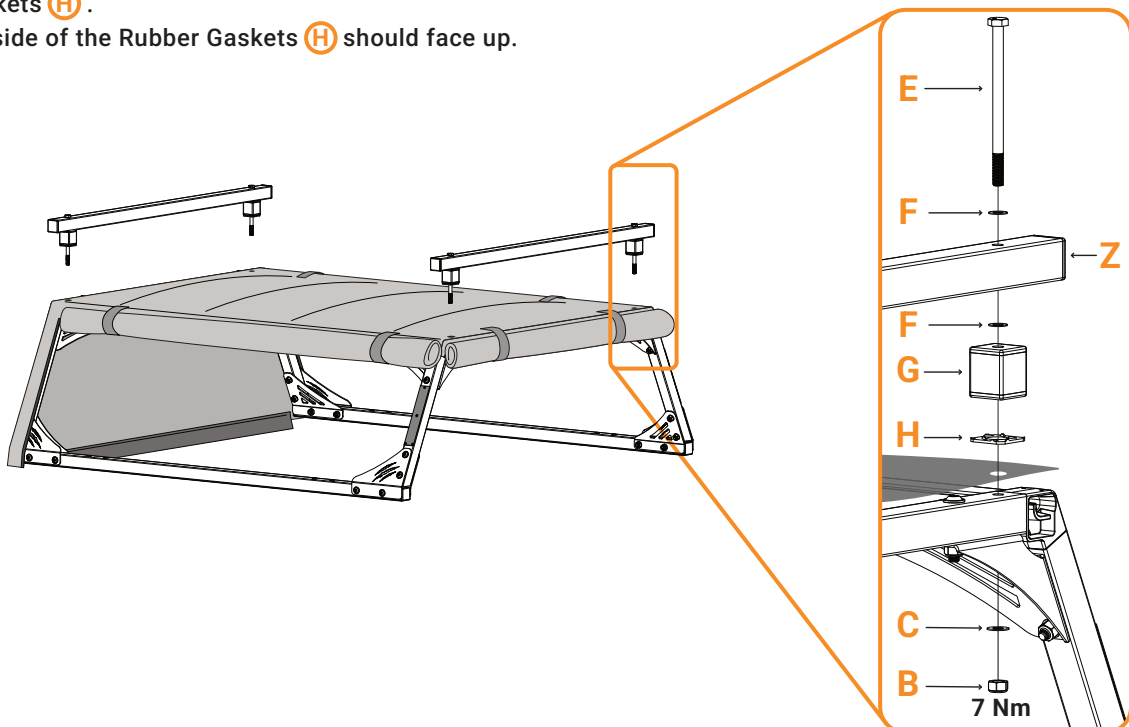

STEP 8 - FIT TO THE VEHICLE

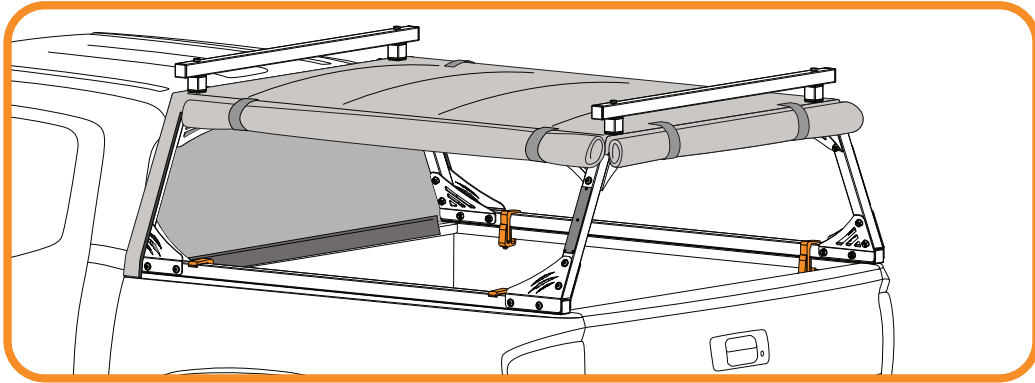

STEP 8.1 - Position Frame on the Vehicle

Lift the frame onto the vehicle and position it so the Cover sits evenly around the top edge of the bed. This step is easiest with a second person. You may also want to close the zips to check how the cover fits. Adjust the frame forward or backward as needed until the Cover fits evenly. For detailed measurements and locating instructions specific to your vehicle, refer to the alignment guide in the Appendix.



Honda Ridgeline and Jeep Gladiator Models have an additional step here (Internal Rail Attachment)
See Appendix before completing this step.

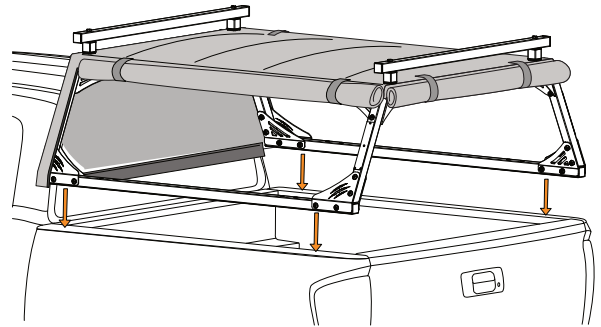

L-Bracket Models

OR

Clamp-On Models

STEP 8.2 (L-Bracket) - Attach the frame to the Vehicle

Insert the provided Rectangle Nuts **O** into the track.

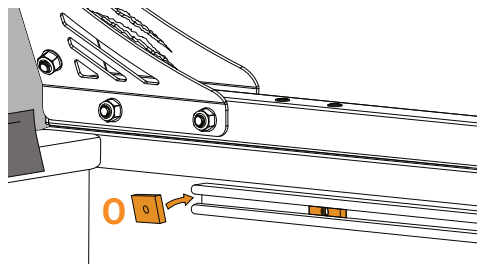

Then bolt L-Brackets **Y** into place

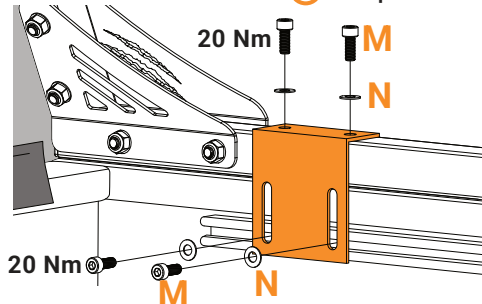

STEP 8.2 (Clamps) - Attach the frame to the Vehicle

Place Clamps **X** as far apart and as close to the frame's Brackets **U** as the vehicle bed allows. Then tighten Clamps.

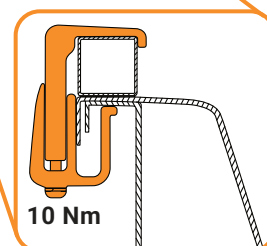
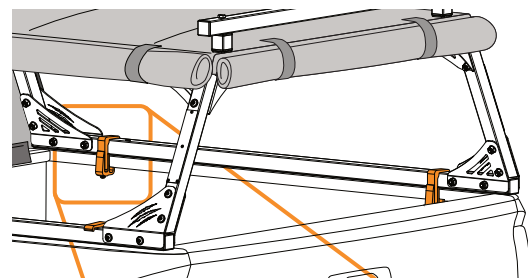



STEP 9 - MAKE IT ROAD READY

STEP 9.1 - Attach the front of cap to the truck bed

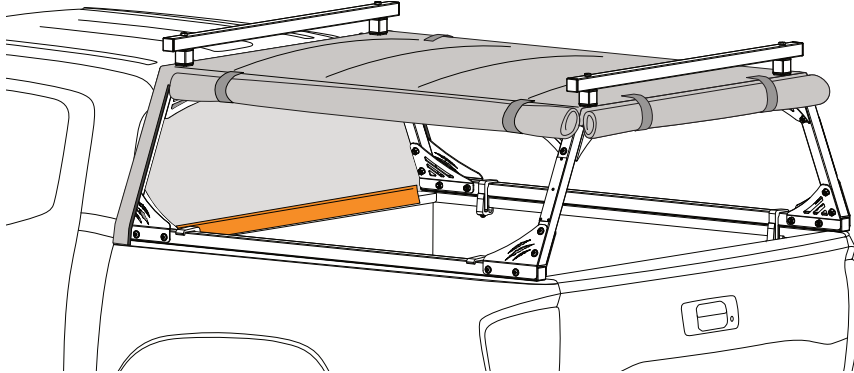
Once the Velcro adhesive from Step 1 has cured for 24 hours, pull the front panel down to reduce any slack in the canvas and attach the Velcro flap (sewn into the cover) onto the Velcro strips on the bed.



STEP 9.2 - Attach the paint protection disks

Clean any dust or dirt from the area under any zips or magnets with a clean cloth and then wipe with the provided Surface Cleaning Wipe . Let the surface dry. Then apply one Paint Protection Disk  to the vehicle directly under each of the zips and on some models, under the magnets.

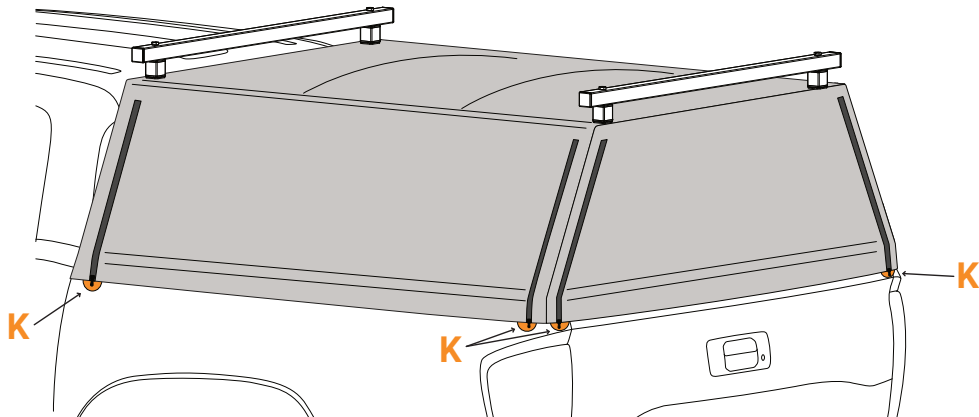

APPENDIX - TRUCK SPECIFIC STEPS

FORD MAVERICK + HONDA RIDGELINE

4.1 - Front Rail Installation

Bolt the supplied Corner Angle bracket to the Inner Bracket **U** as shown.

Place the Front Rail between the Inner Brackets **U** ensuring the Adhesive Rubber is on the bottom face and the plastic End Cap is making contact with the Inner Bracket **U**.

Then, using a #2 Phillips bit and Self-Tapping Screw **D**, screw in the Front Rail to the Corner Angle.

Repeat for the other side.

Once the front rail is installed, attach the Velcro Strips to the front rail as described in Step 1. Then continue with the main instructions from Step 4.1

Note that later in Step 7, when positioning the frame onto the bed, this front rail will need to be positioned at the cabin side (not over the tailgate).

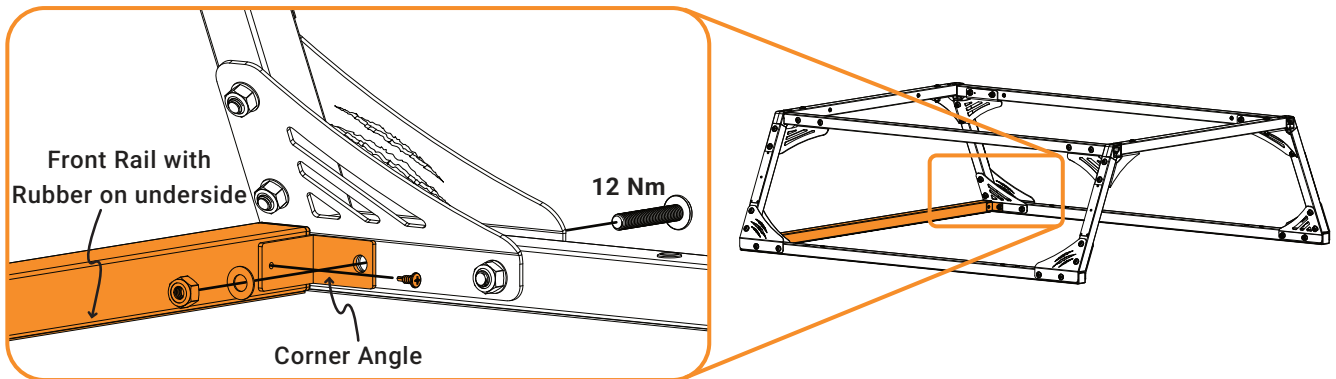

JEEP GLADIATOR + HONDA RIDGELINE

8.1 - Internal Rail attachment

Attach the Internal Rail to the inside wall of the truck bed by fastening the M6 bolts through the drilled holes in the Internal Rail and into the factory bolt holes in the truck bed. Removal of factory bolts may be required.

- Jeep Gladiator: uses 4 x M6 bolts per rail.
- Honda Ridgeline: uses 3 x M6 bolts per rail.

For the Honda Ridgeline, the rivet nuts in the rail should be positioned on the top half, while the drilled holes should be on the lower half, as shown below. Note that the Ridgeline uses left- and right-hand specific rails. If a rail doesn't fit on one side, install it on the opposite side.

After both rails are installed, continue on with the main instructions from step 8.1

Step 8.2 will use the L-Bracket option bolted directly into the Internal rail you just installed.

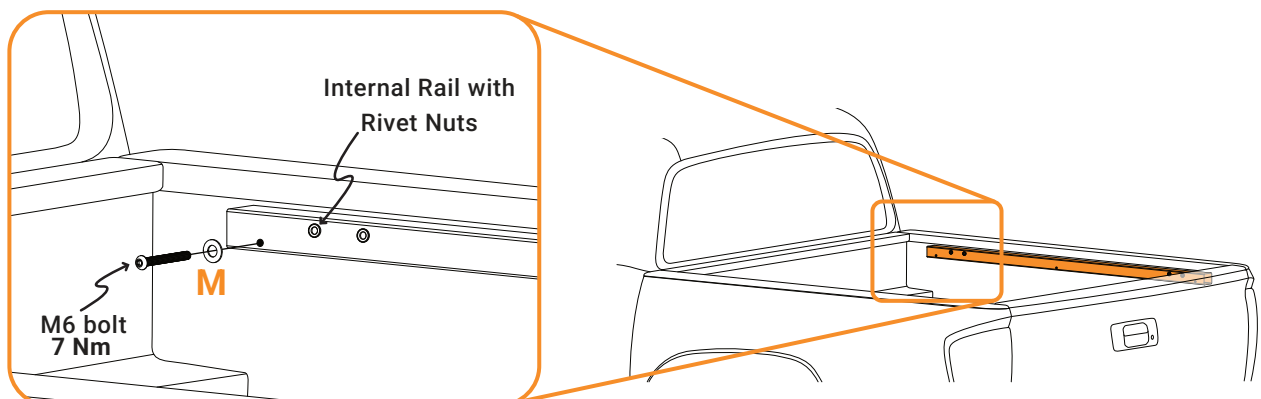

APPENDIX - TRUCK SPECIFIC STEPS

8.1 - Position Frame on the Vehicle (Frame Alignment Table)

Vehicle Description	SKU	Attachment Method	Note
BYD Shark6, 2025-Current, Dual Cab	WTN11784	C	40mm
Chevrolet Colorado, 2015-2022, Long Box	WTN11818	A	
Chevrolet Colorado, 2015-2022, Short Box	WTN11819	C	35mm
Chevrolet Colorado, 2023-Current, Short Box	WTN11820	C	57mm
Chevrolet Silverado 1500, 2007-2013, Standard Box	WTN11916	A	
Chevrolet Silverado 1500, 2014-2018, Short Box	WTN11821	A	
Chevrolet Silverado 1500, 2014-2018, Standard Box	WTN11822	C	13mm
Chevrolet Silverado 1500, 2019-Current, Short Bed	WTN11823	C	47mm
Chevrolet Silverado 1500, 2019-Current, Standard Bed	WTN11864	A	
Ford F-150 Lightning, 2022-2025, 5.5' Box	WTN11755	A	
Ford F-150, 1997-2003, 6.5ft Styleside Box	WTN11824	B	
Ford F-150, 2004-2008, 6.5ft Styleside Box	WTN11825	C	13mm
Ford F-150, 2009-2014, 5.5ft Styleside Box	WTN11826	B	
Ford F-150, 2009-2014, 6.5ft Styleside Box	WTN11827	A	
Ford F-150, 2015-2020, 5.5ft	WTN11713	A	
Ford F-150, 2015-2020, 6.5ft	WTN11828	C	57mm
Ford F-150, 2021-Current, 5.5ft	WTN11755	A	
Ford F-150, 2021-Current, 6.5ft	WTN11828	C	57mm
Ford F-250/F-350, 2017-2022, 6.75ft Box	WTN11915	A	
Ford F-250/350, 2023-Current, 6.75ft Box	WTN11920	C	57mm
Ford Maverick, 2022-Current, 4.5 ft	WTN11829	C	40mm
Ford Ranger (International), 2011-2022, Dual Cab	WTN11886	A	
Ford Ranger (International), 2011-2022, Super Cab	WTN11887	A	
Ford Ranger (International), 2022-Current, Dual Cab	WTN11831	A	
Ford Ranger (US), 2019-2023, 5ft Box	WTN11830	A	
Ford Ranger (US), 2024-Current, 5ft Box	WTN11831	A	
GMC Canyon, 2015-2022, Long Bed	WTN11818	A	
GMC Canyon, 2015-2022, Short Bed	WTN11819	C	35mm
GMC Canyon, 2023-Current, Short Bed	WTN11820	C	57mm
GMC Sierra 1500, 2007-2013, Standard Box	WTN11916	A	
GMC Sierra 1500, 2014-2018, Short Box	WTN11821	A	
GMC Sierra 1500, 2014-2018, Standard Box	WTN11822	C	13mm
GMC Sierra 1500, 2019-Current, Short Bed	WTN11823	C	47mm
GMC Sierra 1500, 2019-Current, Standard Bed	WTN11864	A	
GWM Cannon Alpha, 2024-Current, Dual Cab	WTN11681	C	43mm
GWM Cannon, 2020-Current, Dual Cab	WTN11774	A	
GWM V200 V240, 2009-2015, Dual Cab	WTN11889	A	
Holden Colorado, 2003-2012, Dual Cab	WTN11801	A	
Holden Colorado, 2012-2021, Dual Cab	WTN11795	A	
Holden Colorado, 2012-2021, Space Cab	WTN11885	A	
Holden Rodeo, 2003-2008, Dual Cab	WTN11803	A	
Honda Ridgeline, 2017-Current, 5'4ft	WTN11853	Internal Rail	
Isuzu D-Max, 2003-2012, Dual Cab	WTN11804	A	
Isuzu D-Max, 2012-2020, Dual Cab	WTN11794	A	

Vehicle Description	SKU	Attachment Method	Note
Isuzu D-Max, 2012-2020, Space Cab	WTN11884	A	
Isuzu D-Max, 2020-Current, Dual Cab	WTN11778	A	
Isuzu D-Max, 2020-Current, Space Cab	WTN11890	A	
Jeep Gladiator, 2020-Current, 60.3" With Trail Rail	WTN11832	A	
Jeep Gladiator, 2020-Current, 60.3" Without Trail Rail	WTN11832	Internal Rail	
LDV T60, 2017-Current, Dual Cab	WTN11793	A	
LDV T60, 2017-Current, Mega Tub	WTN11891	A	
Mazda BT-50, 2011-2020, Dual Cab	WTN11888	A	
Mazda BT-50, 2020-Current, Dual Cab	WTN11779	A	
Mercedes-Benz X-Class, 2017-2021, Dual Cab	WTN11924	A	
Mitsubishi Triton, 2009-2015, Dual Cab	WTN11805	A	
Mitsubishi Triton, 2015-2024, Dual Cab	WTN11785	A	
Mitsubishi Triton, 2024-Current, Dual Cab	WTN11720	A	
Nissan Frontier, 2013-2021, Standard Bed	WTN11863	C	12mm
Nissan Frontier, 2022-Current, Long Bed	WTN11833	C	8mm
Nissan Frontier, 2022-Current, Short Bed	WTN11834	C	12mm
Nissan Navara, 2006-2015, Dual Cab	WTN11782	A	
Nissan Navara, 2015-2021, Dual Cab	WTN11800	A	
Nissan Navara, 2021-Current, Dual Cab	WTN11783	A	
Nissan Navara, 2026-Current, Dual Cab	WTN11925	A	
Nissan Titan, 2016-Current, 5.5ft Bed	WTN11835	D	
Ram 1500 DS (Classic Body Style), 2009-Current, 5'7" Box	WTN11836	C	51mm
Ram 1500 DS (Classic Body Style), 2009-Current, 6'4" Box	WTN11837	C	51mm
Ram 1500 DT (New Body Style), 2019-Current, 5'7" Box	WTN11816	C	51mm
Ram 1500 DT (New Body Style), 2019-Current, 6'4" Box	WTN11817	C	51mm
SsangYong Musso, 2018-Current, LWB	WTN11797	A	
SsangYong Musso, 2018-Current, SWB	WTN11798	A	
Toyota Hilux, 2015-Current, Dual Cab	WTN11780	A	
Toyota Hilux, 2025-Current, Double Cab	WTN11912	A	
Toyota Hilux SR (Headboard), 2025-Current, Double Cab	WTN11903	A	
Toyota Tacoma, 2005-2015, 5ft Bed	WTN11841	D	
Toyota Tacoma, 2005-2015, 6ft Bed	WTN11842	D	
Toyota Tacoma, 2016-2023, 5ft Bed	WTN11843	A	
Toyota Tacoma, 2016-2023, 6ft Bed	WTN11844	A	
Toyota Tacoma, 2024-Current, 5ft Bed	WTN11840	A	
Toyota Tacoma, 2024-Current, 6ft Bed	WTN11839	A	
Toyota Tundra, 2007-2013, Short Bed	WTN11845	C	51mm
Toyota Tundra, 2007-2013, Standard Bed	WTN11846	A	
Toyota Tundra, 2014-2021, Short Bed (66.7 in)	WTN11869	C	51mm
Toyota Tundra, 2014-2021, Standard Bed (78.7 in)	WTN11838	A	
Toyota Tundra, 2022-Current, 5.5ft (65.6 in)	WTN11847	B	
Toyota Tundra, 2022-Current, 6.5ft (77.6 in)	WTN11848	C	28mm
Volkswagen Amarok, 2011-2023, Dual Cab	WTN11775	A	
Volkswagen Amarok, 2023-Current, Dual Cab	WTN11892	A	

APPENDIX - TRUCK SPECIFIC STEPS

8.1 - Position Frame on the Vehicle (Alignment Guide)

Check the Table on the previous page to find the attachment method that best suits your vehicle model. The diagrams below illustrate how the frame should be aligned with the truck bed.

Attachment Method A
(Align with Front External Edge)

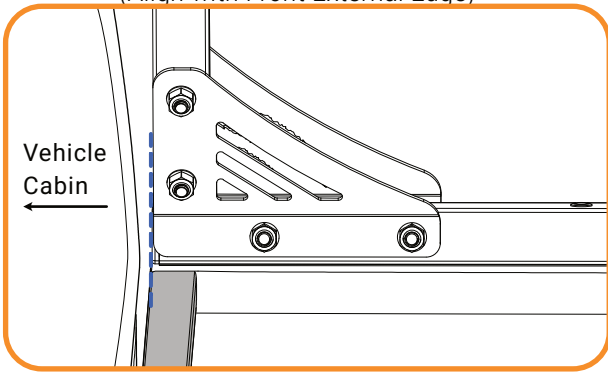

Attachment Method B
(Align with Front Internal Edge)

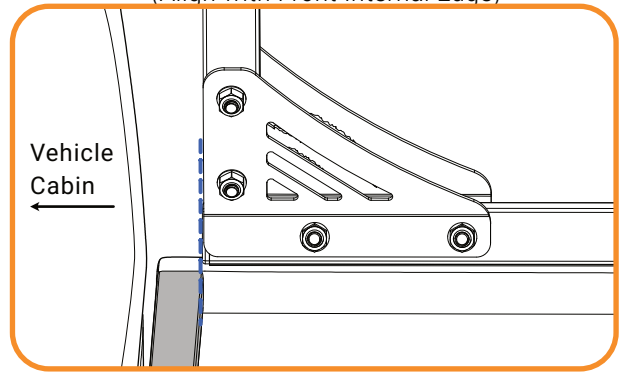

Attachment Method C
(Offset from Front Internal Edge)

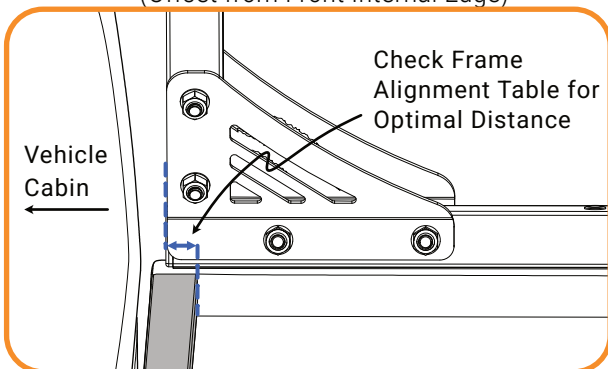

Attachment Method D
(Aligned with Tailgate)

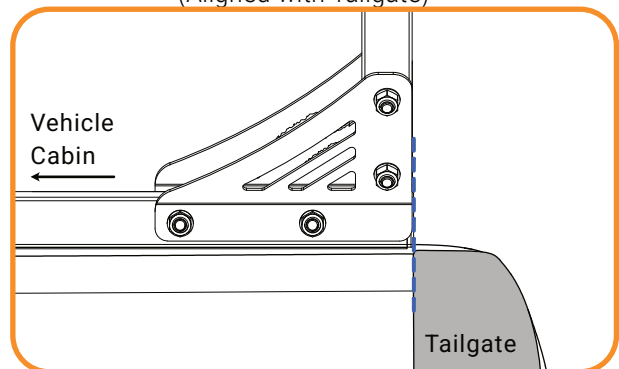

MAINTENANCE & CARE INSTRUCTIONS

Thank you for choosing a Wildtop truck cap for your vehicle! Our caps are built to last, providing you with the durability and functionality you need. However, to ensure the longevity of your truck cap, it is crucial that you follow these maintenance and care instructions carefully.

Zippers

One key aspect of your truck cap maintenance involves the zippers. Dust or dirt may accumulate in the zipper teeth over time, especially if you are frequently in dusty or sandy environments. If such accumulation occurs, please avoid forcing the zipper open or closed, as it may cause damage. Instead, it is recommended that you wash the zipper teeth gently to remove any lodged debris. If the debris is stubborn, use a gentle brush. Dry zippers after.

Canvas

The premium canvas of your truck cap also requires special care to maintain its physical performance and aesthetic lustre. In particular, the waterproof performance of the canvas can be improved through proper conditioning. To condition the canvas, start by fitting the cap to your truck. Then thoroughly wet the canvas with a garden hose, making sure to cover both the inside and the outside. Allow the cap to fully dry, preferably in the sun. Repeat 2 or 3 more times. This allows the fabric to settle after transport and packaging.

The following key points will help maximise the durability and life of your canvas:

- ☞ To remove dirt, brush the fabric with a soft bristle brush. An occasional hosing may remove dust and some ingrained dirt.
- ☞ Never scrub the canvas fabric.
- ☞ Do not expose to petrol or oil.
- ☞ Immediately remove deposits of organic matter (such as soil, grass, bird droppings).
- ☞ Remove any mildew, as it appears, first by brushing, then by treating with diluted chlorine bleach (typically 1 part household grade bleach to 4 parts water to achieve 1% available chlorine). Allow to dry in the sun, then hose well to remove any residue.
- ☞ Do not use strong bleach such as 'pool chlorine'.
- ☞ Do not use soaps, detergents, solvents, or other liquid cleaners.

By following these instructions, you can extend the life of your soft truck cap, maintain its aesthetic appeal, and enhance its functional performance. We want your experience with our product to be nothing short of exceptional, and your care in maintaining your truck cap is a significant part of that. Thank you for your cooperation and enjoy your Wildtop truck cap!

IMPORTANT INFORMATION

Safety

Regularly check the tightness of the fasteners.

Load must be evenly distributed on Ladder Racks and adequately secured.

DO NOT EXCEED 220 lbs (100 kg) Dynamic and 770 lbs (350 kg) Static weight limit on Ladder Racks

Load Carrying Requirements and Recommendations

Weight limits have been tested on the truck cap frame itself, distributed evenly across ladder racks. This does not mean the vehicle bed is capable of such weights. Consult your vehicle manufacturer for further details.

The load must be evenly distributed over the area of the Ladder Rack system, and the center of gravity of the load kept as low as possible. Loads which overhang the ends of the carrier system must conform to any relevant laws or by-laws in your area, and shall be adequately secured.

Loads must be adequately secured using suitable straps or similar tightening and locking devices. The security of the load and roof load carrier shall be checked after loading and regularly throughout the journey. Elastic straps must not be used. The user is warned to maintain and to use straps in working order

It is recommended that items which may produce significant lifting forces (surfboard, sailboard, etc) are not carried side-by-side, but in such a way that lifting force is minimized, securing them independently to the front and rear of the vehicle using straps or other methods which are capable of withstanding the lifting forces. Elastic straps must not be used. Where specialized accessories are available to carry or secure loads, it is recommended that they are used.

The handling characteristics of a vehicle (in particular crosswind sensitivity, handling on bends and braking) change when a carrier system is fitted and especially if that system is loaded. Driving techniques should be altered to allow for these changes, speed reduced, especially on bends, and braking distances made greater.

Send us a photo of your WildTop!

Happy with how your truck top turned out?
Please send us a photo to: info@wild-top.com

